

ECONOMIC GROWTH CENTER

YALE UNIVERSITY

Box 1987, Yale Station
New Haven, Connecticut 06520

CENTER DISCUSSION PAPER NO. 642

SAVING AND ENDOGENOUS GROWTH:
A SURVEY OF THEORY AND POLICY

Willem H. Buiter
Yale University

September 1991

Notes: Center Discussion Papers are preliminary materials circulated to stimulate discussion and critical comments.

The first draft of this paper was written while Professor Buiter was a Visiting Scholar in the Research Department of the International Monetary Fund.

The views expressed in this paper are those of the author and are not to be interpreted as necessarily indicating the position of the Executive Board of the International Monetary Fund.

I would like to thank Xavier Sala-i-Martin for helpful comments on the first draft of this paper and Ken Kletzer for many useful discussions on the general subject of overlapping generation models and endogenous growth.

Saving and Endogenous Growth: A Survey of Theory and Policy

Abstract

The paper surveys and extends recent results on the effect of changes in government fiscal and financial policy and in private savings behavior on economic growth. Private saving behavior is represented by an OLG model. The supply side of the model permits endogenous growth through aggregate constant returns to an augmentable input. Private sector behavior is parameterized with the time preference rate, the intertemporal elasticity of substitution, the birth rate, the death rate and the rate at which labor productivity declines with age. Fiscal instruments include public consumption spending, the capital income tax rate, deficit financing and balanced-budget intergenerational redistribution (an unfunded social security retirement scheme).

(I) Introduction

The study of saving behavior has been a central theme of economics since the days the subject was known as political economy. This paper aims to provide a broad-ranging survey of some of the key issues involving the determinants of the savings rate and the consequences of different kinds of savings behavior for economic growth. It brings together and in minor ways extends results on overlapping generations (OLG) models and endogenous growth by Alogoskoufis and van der Ploeg [1990a,b, 1991], Saint-Paul [1990], Jones and Manuelli [1990] and Buiter and Kletzer [1991a,b,c].

Saving behavior, abstaining from current consumption, is one of two key determinants of economic growth. The other is the efficiency with which the resources that are saved are invested, that is, channeled into and allocated among alternative productive uses. This paper will focus exclusively on the first issue: how much is saved. The view that saving is a key determinant of long-run potential output growth has not been popular since the early 60's when the empirical study of aggregate production functions purported to show that the output elasticity of physical capital was low and that technological change, which was modeled as exogenous, accounted for a large fraction of the growth of output per worker (Solow [1957]).

A broader view of what constitutes investment, which encompasses R&D, additions to the stock of knowledge and human capital accumulation (formal and informal education, on the job training etc.) has necessitated a broader view of what constitutes saving. Technical change has been endogenized and our view of the role of saving in the growth process has been correspondingly broadened. Where the old "exogenous growth" literature attributed to saving behavior at most a permanent effect on the *level* of per capita income but only

a transitory effect on the *rate of growth* of per capita income, the new "endogenous growth" literature implies that differences in saving behaviour will have permanent effects both on growth rates and levels of per capita income. (See e.g. Romer [1986, 1990], Lucas [1988], Barro [1990], Barro and Sala-i-Martin [1990], Sala-i-Martin [1991a,b], Grossman and Helpman [1991] and Helpman [1991]).

The issue can be put very simply. The aggregate production function for the economy we are considering is linear in the aggregate capital stock, that is $Y = aK$, where Y is real output, K is the aggregate capital stock and a is some positive constant. Consider a closed economy without government. Capital depreciation is ignored. Let s denote the ratio of private saving to output. It follows that the growth rate of capital (and thus of output) is

$$\text{given by } \frac{\dot{K}}{K} = \frac{\dot{Y}}{Y} = sa.$$

With constant returns to a factor (or to factors) that can be accumulated, anything that raises the savings rate s or the productivity of the accumulated factor(s) a will raise the growth rate of the economy. This paper focuses on the determinants of s . The determinants of a are not considered.

Differences in savings behaviour may be due to a variety of factors. One important set of determinants of saving are private preferences, that is private attitudes towards intertemporal choice. In standard neo-classical theory this is captured in such features of the preference ordering as the psychological or subjective pure rate of time preference, the intertemporal elasticity of substitution, attitudes towards intergenerational gifts and bequests and the parameters governing the precautionary demand for saving.¹ A second set of influences on private sector saving behaviour is the nature of

private sector anticipations concerning future asset returns and after-tax non-asset income. These can range all the way from Muth-rational expectations to myopic, adaptive or other behavioral hypotheses.

Demographic features constitute a third set of influences on private saving behaviour. While the current age composition of the population must to a large extent be viewed as predetermined, that is, not subject to current public or private choice, its evolution over time will be influenced by private choices impinging on birth and death rates. Government policy too can influence the evolution of the demographic structure, both directly and by influencing private choices co-determining birth and death rates.

Finally, even for a given demographic structure, government policy can influence both the private and the total national (private plus public) saving rate. This can be done through policies involving redistribution among heterogeneous consumers (such as deficit financing and unfunded social security retirement schemes) and through policies that alter the opportunity cost of saving.

Endogenous growth theory has amplified the effects of changes in parameters and exogenous variables.² Since the impact of policy on long-run growth has slipped a derivative, special attention will be given in this paper to the way in which economic policy influences saving. Among the policy instruments that will be considered are unfunded social security retirement schemes, deficit finance, the taxation of wage and non-wage income, interest taxes and subsidies and public consumption spending. The relationship between private and public saving (the financial crowding out issue) has of course long been a central theme of macroeconomics.

The linearity of the aggregate production function in the aggregate capital stock represents a considerable simplification the global dynamics of

capital, output and consumption, when compared to the neoclassical exogenous growth model with constant returns to capital and the non-augmentable factor labor jointly. As will become clear in Section VI, by expressing stocks and flows as ratios to the capital stock, the dynamic analysis involves one fewer state variable than the corresponding exogenous growth model. The model is therefore a useful didactic tool for a first introduction to growth theory.

Limitations of space restrict the scope of this paper to the link between saving and long-term growth. This means in particular that I omit consideration of the cyclical relationship between private and public saving behavior and private investment, and of the role of fiscal and financial stabilization policy. The separation of the saving decision from the investment decision in modern capitalist economies with, to a first approximation, households doing the saving (in the form of accumulation of financial assets) and firms making the capital accumulation and R & D decisions, creates the possibility of intertemporal coordination failure, where the ex-post balancing of saving and investment occurs at a socially inefficient level. Asymmetric information between borrowers (investing firms) and lenders (saving households) may result in incompleteness of the set of contingent forward markets. Financial intermediaries may emerge that help overcome or at least mitigate the failure of market prices to convey all information necessary for efficient saving and investment decisions. If this is not privately rational, welfare-improving fiscal or regulatory interventions may exist. The beginnings of rigorous analytical underpinnings to a formal theory of financial market failure along these lines can be found in the work of Bernanke and Gertler [1987].

The plan of the paper is as follows. Section II develops the private consumption side of the model. Section III restates the necessary and

sufficient conditions for absence of debt neutrality in the OLG model under consideration. Section IV discusses the impact effect on saving of the social security retirement scheme first formalized by Saint-Paul [1990]. Section V introduces a very simple model of the supply side that is consistent with endogenous growth in an OLG setting. The structure of property rights, together with the technology, permits new generations to participate in the market game with endowments whose value increases in line with the growth rate.³

In Section VI I investigate the effects of changes in the parameters characterizing tastes (the time preference rate, the elasticity of intertemporal substitution), demography (the birth rate, the age-dependent labor power depreciation rate and the death rate) and fiscal policy (public debt, labor income taxes, the parameters describing the unfunded social security retirement scheme, the tax rates on capital rental income and on interest income and exhaustive public consumption spending). Section VII concludes.

(II) The demand side of the model.

(a) Private consumption.

Private consumption is given by the overlapping generations model of Blanchard [1985] and Weil [1990] as synthesized in Buiter [1988]. At each instant t a consumer born at time $s \leq t$ solves the following optimum problem:

$$(1) \quad \max_{\{\bar{c}(s,v)\}} E_t \int_t^{\infty} \frac{1}{1-\gamma} \bar{c}(s,v)^{1-\gamma} \{\exp[-\rho(v-t)]\} dv \quad \rho, \gamma > 0 \quad 4$$

$$\bar{c}(s,v) \geq 0 \text{ for all } s \text{ and for all } v \geq s.$$

Subject to the budget identity

$$(2) \quad \frac{d}{dt} \bar{a}(s,t) \equiv (r(t) + \lambda)\bar{a}(s,t) + \bar{x}(s,t) - \bar{\tau}(s,t) - \bar{c}(s,t)$$

and the solvency constraint

$$(3) \quad \lim_{\ell \rightarrow \infty} \bar{a}(s,\ell) \exp\left\{-\int_t^\ell [r(u) + \lambda] du\right\} = 0.$$

We also have

$$(4a) \quad \bar{x}(s,t) = w(s,t)\bar{j}(s,t)$$

$$(4b) \quad w(s,t) = w(t) \quad \text{for all } s$$

$$(4c) \quad \bar{j}(s,t) = \bar{j}(t,t)e^{-\pi(t-s)} \quad s \leq t$$

E_t is the expectation operator, conditional on information at time t . γ is the elasticity of instantaneous marginal utility or the reciprocal of the intertemporal elasticity of substitution: a larger value of γ indicates a stronger desire to smooth consumption over time. ρ is the subjective rate of time preference, $\bar{c}(s,v)$ is consumption at time v by someone born at time s , \bar{a} denotes financial wealth, \bar{x} is the individual's labor income, w is the wage rate or the rental rate of human capital, \bar{j} is the amount of labor power (in efficiency units) applied by the individual, $\bar{\tau}$ is the amount of lump-sum taxes net of transfers on labor income and r is the real interest rate. Each consumer faces a time and age independent instantaneous probability of death,

$\lambda \geq 0$. Everyone currently alive will therefore, regardless of age, have the same life expectancy $1/\lambda$. This is of course very poor demography and it also means that the theory cannot expect to capture most of the life cycle effects on saving. Human capital is homogeneous and its rental rate is the same for everyone currently alive (4b). Equation (4c) says that the human capital of a person born in period s equals that of a person born in period t times a factor $e^{-\pi(t-s)}$. This can be interpreted as aging leading to the erosion, at the constant exponential rate π , of the raw labor endowment of an individual.

The term $\lambda \bar{a}$ on the right-hand side of equation (2) is due to the presence of efficient annuities markets. Consumers contract with annuities companies to receive a rate of return \aleph on their financial wealth at each instant. When they die, their entire financial wealth goes to the annuity company. The annuities industry is competitive, risk neutral and has free entry. λ is both the instantaneous probability of death and the fraction of each (large) age cohort (and therefore of the total population) that dies at each instant. The zero expected profit condition implies that $\aleph = \lambda$.

I define human capital $\bar{h}(s,t)$ to be the present discounted value at time t (using the "risk-of-death-corrected" individual discount rate $r + \lambda$) of expected future *before-tax* labor income of someone born at time $s \leq t$.

$$(5a) \quad \bar{h}(s,t) \equiv \int_t^{\infty} \bar{x}(s,v) (\exp\{-\int_t^v [r(u)+\lambda] du\}) dv$$

Similarly I define $\bar{\theta}(s,t)$ as the present discounted value, at time t , of the life-time taxes expected to be paid by a household born in period s , that is

$$(5b) \quad \bar{\theta}(s,t) \equiv \int_t^{\infty} \bar{\tau}(s,v) e^{-\int_t^v (r(u)+\lambda) du} dv$$

Under rational expectations ⁵, the solution to the consumer's problem is

$$(6a) \quad \bar{c}(s,t) = \eta(t) [\bar{a}(s,t) + \bar{h}(s,t) - \bar{\theta}(s,t)]$$

$$(6b) \quad \eta(t) = \left[\int_t^{\infty} \left\{ \exp \left[-\left(\frac{\gamma-1}{\gamma} \right) \int_t^v r(u) du + (v-t) \left(\lambda + \frac{1}{\gamma} \rho \right) \right] \right\} dv \right]^{-1}$$

Note that this implies that:

$$(6c) \quad \frac{d}{dt} \bar{c}(s,t) = \gamma^{-1} (r - \rho) \bar{c}(s,t) \quad 6$$

(b) Aggregation

Without loss of generality I set $\mathfrak{N}(0)$, population at time zero, equal to 1, that is $\mathfrak{N}(0) = 1$. In addition to the constant death rate $\lambda \geq 0$ there is a constant birth rate $\beta \geq 0$. The rate of growth of population n is therefore constant and given by $n = \beta - \lambda$, that is $\mathfrak{N}(t) = e^{(\beta-\lambda)t} = e^{nt}$. Note that, when $\beta > 0$, total population at time t can be written as the sum of all survivors of previous generations, that is $\mathfrak{N}(t) = \beta e^{-\lambda t} \int_{-\infty}^t e^{\beta s} ds$. Raw labor power is assumed to decline with age at a constant proportional rate π . Let $\ell(s,t)$ be the raw labor power supplied at time t by the surviving members of generation s and $n(s,t)$ the number of members of generation s surviving at time t . It follows that $\ell(s,t) = n(s,t) e^{-\pi(t-s)} = \beta e^{[(\beta+\pi)s - (\lambda+\pi)t]}$. Summing over all past generations yields the aggregate supply of raw labor

power, $L(t)$, given in equation (7).

$$(7) \quad L(t) = \frac{\beta}{\beta + \pi} e^{nt}.$$

Corresponding to any individual flow or stock variable $\bar{v}(s,t)$ I define the corresponding population aggregate $V(t)$ to be $V(t) = \beta e^{-\lambda t} \int_{-\infty}^t \bar{v}(s,t) e^{\beta s} ds$ if $\beta > 0$ and $V(t) = \bar{v}(s,t) e^{-\lambda t}$ if $\beta = 0$. Special mention deserves $\Theta(t)$, the present discounted value, at time t , of the expected life-time taxes to be paid by all those currently alive, which is given by

$$(8) \quad \Theta(t) \equiv \beta e^{-\lambda t} \int_{-\infty}^t \theta(s,t) e^{\beta s} ds$$

Lump-sum taxes (net of transfers) are assumed to vary with age in the following manner. Lump-sum taxes paid by a member of generation $s \leq t$, $\bar{\tau}(s,t)$, are the sum of an age-independent component, t_0 and an age-dependent component $t_1 e^{t_2(t-s)}$ which grows exponentially with age, as shown in equation (9). In order to obtain, for the study of long-run effects of tax changes in Section (IV), dynamic systems with an interesting steady state, it is also assumed that individual taxes include a "scale component" $\epsilon(t)$, which for the moment I only require to be positive.

$$(9) \quad \bar{\tau}(s,t) = [t_0 + t_1 e^{t_2(t-s)}] \epsilon(t)$$

Provided $\beta > t_2$, a necessary condition for total tax receipts to be bounded, total tax revenue at each instant t is given by:

$$(10) \quad T(t) \equiv \beta e^{-\lambda t} \int_{-\infty}^t \bar{r}(s, t) e^{\beta s} ds = \epsilon(t) \left[t_0 + t_1 \left(\frac{\beta}{\beta - t_2} \right) \right] e^{nt}$$

Since there are neither voluntary nor involuntary ⁷ bequests in our model, people are born without financial assets or liabilities, that is $\bar{a}(s, s) = 0$. It follows that aggregate consumption is given by:

$$(11) \quad C(t) = \eta(t) [A(t) + H(t) - \Theta(t)]$$

where η is defined in equation (6b) and

$$(12) \quad \dot{A}(t) = r(t)A(t) + X(t) - T(t) - C(t)$$

$$(13) \quad \dot{H}(t) = (r(t) + \beta + \pi)H(t) - X(t)$$

$$(14) \quad \dot{\Theta}(t) = (r(t) + \beta)\Theta(t) - T(t) - \Omega(t)$$

where

$$(15) \quad \Omega(t) \equiv \beta e^{nt} \left[\frac{t_1 t_2}{\beta - t_2} \right] \int_t^{\infty} \epsilon(z) e^{-\int_t^z (r(q) + \lambda - t_2) dq} dz$$

Integrating (13) forward, the aggregate human capital of those currently alive can be written as in equation (16a) and the aggregate tax burden faced by those currently alive as in equation (16b)

$$(16a) \quad H(t) = \int_t^{\infty} X(v) e^{-\int_t^v (r(u) + \beta + \pi) du} dv$$

$$(16b) \quad \Theta(t) = \int_t^{\infty} [T(v) + \Omega(v)] e^{-\int_t^v (r(u) + \beta) du} dv$$

The term π is present in the discount rate for human capital income in equation (16a) but not in the discount rate for future taxes in equation (16b) because the depreciation of raw labor power with age, at a constant rate π , only affects the before-tax component of labor income and not the tax bill. The term Ω on the right-hand side of equations (14) and (16b) is present if and only if there are age-dependent lump-sum taxes, that is if both t_1 and t_2 are non-zero and if the birth rate is positive. $\Omega(t)$ represents the contribution by those born at time t to the rate of change in the age-dependent component of the tax burden.

Ignoring Ω for the moment, we see that $H(t)$, the aggregate human capital of those currently alive, is the present discounted value of future after-tax wage income, where the discount rate is the real interest rate augmented by the birth rate β and the rate of labor power depreciation π . The presence of the birth rate signals that the future expected labor income of "new entrants" (those born after time t) is not owned by anyone currently alive. An operative intergenerational gift and bequest motive would cause the discount premium associated with β to disappear. So of course would a zero birth rate or a different structure of labor property rights, such as a society in which all labor is performed by people subject to hereditary slavery (see Buiter [1989]). In the Blanchard-Weil OLG model an "owner-occupier"

system of labor property rights, taxation of labor income and a positive birth rate are necessary and sufficient for absence of debt neutrality. Uncertain lifetimes ($\lambda > 0$) do not belong to the set of necessary and sufficient conditions.

Equations (11) to (15) plus the definition of η in (6b) imply that the rate of change of aggregate consumption can be written as

$$(17) \quad \dot{C} = [\gamma^{-1}(r - \rho) + n + \pi]C - \eta(\beta + \pi)A + \eta\Omega + \pi\eta\Theta$$

(c) The government.

At each instant t the government spends an amount $G(t) \geq 0$ on public consumption ⁸, raises tax revenues $T(t)$ and finances any excess of current outlays over current revenues by issuing fixed real market value, variable interest rate bonds. Monetary financing is not considered. The stock of these bonds is denoted $B(t)$. The government budget identity is given in (18). Together with its solvency constraint, given in (19) it implies the governments intertemporal budget constraint given in (20): the current debt should equal the present discounted value of future primary (non-interest) surpluses.

$$(18) \quad \dot{B}(t) \equiv r(t)B(t) + G(t) - T(t)$$

$$(19) \quad \lim_{\ell \rightarrow \infty} B(\ell) \exp\left[-\int_t^\ell r(u)du\right] = 0.$$

$$(20) \quad B(t) = \int_t^\infty [T(v) - G(v)] \left\{ \exp\left[-\int_t^v r(u)du\right] \right\} dv$$

(d) Equilibrium.

Markets clear at each instant. In this closed economy real reproducible capital, K , and government debt are the only non-human stores of value. Financial market equilibrium therefore requires that (21) holds for all t .

$$(21) \quad A(t) = K(t) + B(t)$$

Capital accumulation is governed by

$$(22) \quad \dot{K} = Y - \delta K - C - G$$

where Y is gross real output and $\delta > 0$ the instantaneous rate of depreciation of capital.

(III) Debt neutrality.

In this section I briefly review the necessary and sufficient condition for debt neutrality in our consumption model. None of the results of this Section depend on the model of production.

I proceed as follows. Into the aggregate consumption function given in equation (11) we substitute for A using equation (21), for H using equation (16a) and for Θ using equation (16b). Then add and subtract the term

$\int_t^{\infty} G(v) \exp\{-\int_t^v [r(u) + \beta] du\}$ and rearrange. This yields equation (23). When we

replace this last step by the elimination of $B(t)$ from the aggregate private consumption function using the public sector intertemporal budget constraint

(20), equation (24) results. For easy reference, the definition of η is reproduced as well.

$$\begin{aligned}
 (23) \quad C(t) &= \eta(t) \left[K(t) + \int_t^{\infty} [X(v) e^{-\int_t^v (r(u) + \beta + \pi) du} - G(v) e^{-\int_t^v (r(u) + \beta) du}] dv \right] \\
 &+ \eta(t) \left[B(t) - \int_t^{\infty} [T(v) - G(v) + \beta e^{nv} \left(\frac{t_1 t_2}{\beta - t_2} \right) \int_v^{\infty} \epsilon(z) e^{-\int_v^z (r(q) + \lambda - t_2) dq} dz] e^{-\int_t^v (r(u) + \beta) du} dv \right] \\
 (24) \quad C(t) &= \eta(t) \left[K(t) + \int_t^{\infty} [X(v) e^{-\int_t^v (r(u) + \beta + \pi) du} - G(v) e^{-\int_t^v r(u) du}] dv \right. \\
 &\quad \left. + \int_t^{\infty} \{ T(v) [e^{\beta(v-t)} - 1] \right. \\
 &\quad \left. - \beta e^{nv} \left[\frac{t_1 t_2}{\beta - t_2} \right] \int_v^{\infty} \epsilon(z) e^{-\int_v^z (r(q) + \lambda - t_2) dq} dz \} e^{-\int_t^v (r(u) + \beta) du} dv \right] \\
 \eta(t) &= \left[\int_t^{\infty} \left\{ \exp \left[- \left(\frac{\gamma-1}{\gamma} \right) \int_t^v r(u) du + (v-t) \left(\lambda + \frac{1}{\gamma} \rho \right) \right] \right\} dv \right]^{-1}
 \end{aligned}$$

From the government's intertemporal budget constraint given in equation (20) it is clear that the second term on the right-hand-side of equation (23) is identically equal to zero if and only if the birth rate β equals zero. When that is the case, government debt and the intertemporal distribution of lump-sum taxes do not influence private consumption behaviour. We are effectively (despite the possibility of a positive death rate) in a representative agent model. Debt neutrality breaks down if the intertemporal redistribution of lump-sum taxes associated with government borrowing

redistributes life-time resources between agents that are heterogeneous with respect to their consumption behaviour (see Buiter [1990]). When $\beta = 0$ there are no new agents coming into the system. All those currently alive have the same life expectancy and the same marginal propensities to spend out of comprehensive wealth η .

The same conclusion is reached when I set $\beta = 0$ in equation (24). The third expression inside the big brackets on the right-hand-side of equation (24) disappears in that case. All that matters for aggregate consumption is the government's exhaustive spending program.

(IV) An Unfunded Social Security Retirement Scheme.

Following Saint-Paul [1990], I can analyze the consequences of the introduction (or an increase in the scale of) an unfunded social security retirement scheme by introducing balanced-budget redistribution from the young to the old. Again, the results do not depend on the model of production.

In this Section, I evaluate the impact effect on aggregate consumption of changes in the parameters characterizing the social security retirement scheme, holding constant the initial stocks of capital, K , and government debt, B , and the expected future paths of interest rates, r , and wage income, X , and exhaustive public spending, G .⁹ If aggregate consumption changes as a result of these parameter changes, there are likely to be consequences for the future behaviour of such endogenous variables as output, the capital stock, the wage rate and the interest rate. In Section VI a simple dynamic general equilibrium growth model will be used to evaluate the dynamic responses of these and other endogenous variables.

Saint-Paul [1990] models an increase in the scale of an unfunded social

security retirement scheme as follows.¹⁰ Without loss of generality consider the case where the initial value of t_1 is positive. Consider an increase in t_1 , the amount of tax paid by a newborn. This increase in taxes paid while young is accompanied by a change in the growth rate of the tax burden with age, t_2 , which is just sufficient to keep total tax receipts at each point in time constant. From equation (10) this implies that

$$(25) \quad dt_2 = \left(\frac{t_2 - \beta}{t_1} \right) dt_1$$

Since $\beta > t_2$, an increase in t_1 , with t_1 positive, requires a reduction in t_2 in order for total tax receipts to remain constant: pay more when young and less when old.

Note that, with the tax rule under consideration,

$$\bar{\theta}(s,t) \equiv \int_t^{\infty} \bar{\tau}(s,v) e^{-\int_t^v (r(u)+\lambda) du} dv, \text{ the present discounted value, at time } t, \text{ of}$$

the life-time taxes expected to be paid by a household born in period s is given by

$$\bar{\theta}(s,t) \equiv t_0 \int_t^{\infty} \epsilon(v) e^{-\int_t^v (r(u)+\lambda) du} dv + t_1 e^{t_2(t-s)} \int_t^{\infty} \epsilon(v) e^{-\int_t^v (r(u)+\lambda-t_2) du} dv$$

Therefore, $\Theta(t) \equiv \beta e^{-\lambda t} \int_{-\infty}^t \bar{\theta}(s,t) e^{\beta s} ds$, the present discounted value, at time

t , of the expected life-time taxes to be paid by all those currently alive, is given by

$$(26) \quad \Theta(t) = e^{nt} \left[t_0 \int_t^{\infty} \epsilon(v) e^{-\int_t^v (r(u)+\lambda) du} dv + \left(\frac{t_1 \beta}{\beta - t_2} \right) \int_t^{\infty} \epsilon(v) e^{-\int_t^v (r(u)+\lambda-t_2) du} dv \right]$$

It is easily checked that the effect on $\Theta(t)$ of an increase in t_1 with t_2 reduced so as to keep $T(t)$ constant is given by:

$$(27) \quad \left. \frac{d\Theta(t)}{dt_1} \right|_{dT(t)=0} = -\beta e^{nt} \int_t^{\infty} (v-t) \epsilon(v) e^{-\int_t^v (r(u)+\lambda-t_2) du} dv < 0$$

Balanced-budget redistribution from the young to the old therefore reduces the presented discounted value of the total future taxes to be paid by those currently alive. Since all those currently alive have the same marginal propensities to spend out of comprehensive wealth, the result will be an increase in aggregate private consumption and a reduction in private saving. Since we are considering a balanced-budget operation, total private plus public saving also falls.

(V) The supply side of the model.

To motivate the specification of the production side of the model it is necessary to remember that I am trying to construct the simplest possible competitive endogenous growth model with Yaari-Blanchard-Weil OLG demographics. I therefore want the aggregate production function to be linear in the aggregate capital stock, while the structure of property rights has to be such that in equilibrium new generations are born with endowments whose value rises at the endogenous rate of growth. We cannot achieve both objectives if the individual firm's production function were to be specified as linear in that firm's own capital stock, with no other essential scarce

inputs such as labor, that are typically assumed to be owned by new-born households, even in the absence of private intergenerational gifts. We would be hard pushed to think of a plausible property rights structure that would give the new generations a claim to some share of the capital stock in existence when they are born. One way to ensure that the newborn can join fully in the endogenous growth game is to allow workers to appropriate the quasi-rents created by an economy-production externality. This is the approach adopted here.

The representative firm, i , produces a homogeneous output y_i with a production function, given in equation (28), which is positive for positive inputs, increasing, constant returns to scale in its two inputs, physical capital, K_i and labor input in efficiency units J_i , strictly concave and at least twice continuously differentiable. I define $k_i \equiv K_i/J_i$.

$$(28) \quad y_i = F(K_i, J_i) = J_i f(K_i/J_i) = J_i f(k_i)$$

J_i , which measures the i^{th} firm labor input in efficiency units, is the product of L_i , the quantity of raw labor power hired by firm i and ϵ , the quality index of labor, which is the same for all firms.¹¹ I shall assume that, in the spirit of Sheshinski [1967], quality or efficiency is measured by the economy-wide capital-labor ratio.¹² The interpretation of "capital" should therefore probably rather broader than plant, equipment and structures. Extreme simplicity is the main virtue of this model.

$$(29a) \quad J_i = \epsilon L_i$$

$$(29b) \quad \epsilon = K/L$$

where $K \equiv \sum_{i=1}^N K_i$ and $L \equiv \sum_{i=1}^N L_i$

Firms hire workers and rent capital to maximize profits. They are price takers and also take ϵ to be independent of their own choices of K_i and L_i . This creates a positive externality in the private accumulation of capital and a negative externality in the use of labor.¹³ Let \tilde{w} be the wage of raw labor power (say the rental rate of one hour of labor time, where the hours per worker can vary with age, as determined by the parameter π). It follows that

$$\tilde{w} = \epsilon [f(k_i) - k_i f'(k_i)]$$

The rental of a unit of efficiency labor, w , is of course given by:

$$w = \tilde{w}/\epsilon = f(k_i) - k_i f'(k_i)$$

The private profit maximizing demand for capital is given by

$$r = f'(k_i) - \delta$$

Here $\delta \geq 0$ is the constant exponential rate of depreciation of capital.

Letting $Y \equiv \sum_{i=1}^N y_i$, I aggregate across all firms to get

$Y = \sum_{i=1}^N F(K_i, \frac{K}{L} L_i)$. Using the fact that all firms are identical and the

linear homogeneity of $F(., .)$, the aggregate production function can be

written as

$$Y = F(K, K) = Kf(1)$$

Defining $a = f(1) > 0$, I can write aggregate output as linear in K

$$(30) \quad Y = aK$$

Note that the social return to an additional unit of physical capital is given by $a - \delta = f(1) - \delta$, while the private gross marginal product of capital, which I shall denote a' , is given by $a' \equiv f'(1) < f(1) \equiv a$. Private capital accumulation does not allow for the non-appropriable benefit of raising the average quality of the labor force. In this model, the interest rate and the real wage are fixed by technology and constant:

$$(31) \quad r = f'(1) - \delta = a' - \delta$$

$$(32) \quad w = f(1) - f'(1) = a - a'$$

Since the economy is not viable if the net social marginal product of capital is negative, I assume:

$$a - \delta > 0$$

The net private marginal product of capital can either be positive or negative.

Note that this specification of the production technology would avoid a

problem, signaled by Jones and Manuelli [1990] that can arise in finite-lifetime (Samuelson-Diamond) OLG models of endogenous growth. They consider a model where the one-sector technology of production in principle permits endogenous growth. The consumers' side of the model is the standard two-period Samuelson-Diamond OLG model without intergenerational gifts and bequests, in which the young have a positive endowment of labor that is constant from generation to generation. Growth peters out in the long run because the young generation does not have enough resources to purchase an ever increasing capital stock from the old. Our equations (28) and (29a,b) rule out this problem. The value of the labor endowment per worker, which is constant in physical units, is augmented one-for-one with the aggregate physical capital stock, which increases the efficiency of this physical quantity of labor.

In the Yaari-Blanchard-Weil OLG model of this paper, there is of course no life-cycle pattern of saving. Since everyone, regardless of age, has the same remaining expected lifetime (which may be infinite), the young have the same marginal propensity to consume out of wealth, η , as the old. The Jones and Manuelli problem does show up in another form, however. Alogoskoufis and van der Ploeg [1990a,b, 1991] used the same aggregate production function, given in equation (30) as is used in this paper. The individual firm's production function however, was given by $y_i = F(K_i, K/N)$, $i = 1, \dots, N$, with F linear homogeneous. There is an externality in the use of capital, because each individual firm takes the average capital stock (per firm) K/N as independent of its own choice of K_i . There is no labor input in the production function.

In the description of their model Alogoskoufis and van der Ploeg do not include labor among the productive inputs or endow new generations at birth

with labor or with any other claims on resources that would give them a stake in the economy, let alone a stake that grows in value at the rate required to sustain endogenous growth. In terms of our model of consumption, $\bar{h}(t,t) = 0$, and the newborn cannot get into the game.¹⁴ The model also cannot explain how those already in the game, who own the capital stock, ever got to own any capital if they started off at birth without any claim on valuable scarce resources.¹⁵ The problem is one of property rights assignment. Fortunately, they then proceed as if workers are born endowed with claim on an equal per capita share of the marginal product of K/N . This makes their model effectively equivalent to the one of this paper.

In Buiter and Kletzer [1991a,b] which develops an endogenous growth model with a Samuelson–Diamond (3–period) OLG demographic structure, the endowment of the young grows at a rate sufficient so sustain endogenous growth, but through a different mechanism. Equations (28) and (29a) are kept, but equation (29b) is replaced by something like $\frac{\dot{\epsilon}}{\epsilon} = \xi \left(\frac{\sum e_j}{\epsilon}, \dots \right)$ $\xi_1 > 0$. ϵ may be interpreted as the economy-wide stock of useful knowledge; e_j are the resources (education and training) spent by the j^{th} household to augment its own knowledge and skills. There again is an externality because each household ignores the effect of its own education and training on ϵ , and thus on the productivity of other households currently alive or yet to be born (ϵ does not die when the households that contributed to it die: human capital may die but the stock of useful knowledge survives unscathed). This two capital goods structure permits endogenous growth.¹⁶

The impossibility of dynamic inefficiency.

From equation (22) we get

$$\dot{K}/K = a - \delta - C/K - G/K$$

The growth rate of capital is, since C and G are non-negative, never higher than the net social marginal product of capital. This economy, with its linear technology is therefore never dynamically inefficient.¹⁷ Clearly, a necessary condition for dynamic inefficiency is that the marginal product of capital be able to fall below the average product. With output linear in the capital stock, the social marginal and average products of capital are always equal to each other and constant.¹⁸

(VI) Saving and long-run growth.

To simplify the exposition, I shall start the analysis in this Section with the case of age-independent labor power ($\pi = 0$) and age-independent taxes ($t_1 = 0$ or $t_2 = 0$). Since capital is the natural "scale variable" of this economy, I shall consider the behavior over time of the growth rate of capital, of consumption per unit of capital, $C/K \equiv c$, and of public debt per unit of capital, $B/K \equiv b$. In order for the system to have steady states, I will treat government consumption per unit of capital, $G/K \equiv g$, and lump-sum taxes per unit of capital, $T/K \equiv \tau$, as the policy instruments.

Let $\mathcal{G}_K \equiv \dot{K}/K$. From equations (17), (18), (21), (22), (30), (31) and (32), I obtain the following system of equations, familiar from the work of Alogoskoufis and van der Ploeg [1990a,b]:

$$(33) \quad \mathcal{G}_K = a - \delta - g - c$$

$$(34) \quad \dot{c} = -\eta\beta + [\gamma^{-1}(a' - \delta - \rho) + n - a + \delta + g]c - \eta\beta b + c^2$$

$$(35) \quad \dot{b} = (a' - a + g)b + g - \tau + cb$$

Note that, since r is constant, η is also constant and given by

$$(36) \quad \eta = \left(\frac{\gamma - 1}{\gamma}\right)(a' - \delta) + \lambda + \frac{\rho}{\gamma}$$

I first consider the case where there is no public debt outstanding, $b = 0$, and the budget is balanced continuously through endogenous variations in the ratio of lump-sum, age-independent taxes to aggregate capital, τ .¹⁹

In this case the dynamics of the system is captured by a single quadratic differential equation in consumption per capita:

$$(37) \quad \dot{c} = -\eta\beta + [\gamma^{-1}(a' - \delta - \rho) + n - a + \delta + g]c + c^2$$

Figure 1a shows the parabola representing equation (37) in c - \dot{c} space, referred to henceforth as the *consumption parabola*. There are two stationary equilibria, one for a positive value of c (shown as c_1^*) and one for a negative value (shown as c_2^*).

$$(38) \quad c_{1,2}^* = 0.5 \left[-[\gamma^{-1}(a' - \delta - \rho) + n - a + \delta + g] \pm \{[\gamma^{-1}(a' - \delta - \rho) + n - a + \delta + g]^2 + 4\eta\beta\}^{0.5} \right]$$

Only the positive stationary equilibrium is economically meaningful.

Note that c is a non-predetermined state variable and that c_1^* is an unstable

equilibrium. Figure 1b graphs the inverse (with slope -1) linear relationship between \mathcal{G}_K and c given in equation (33), referred to henceforth as the *capital growth line*. The minimum of the parabola need not be for positive value of c . Even if the economy is viable ($a > \delta$), the intercept of the line $\mathcal{G}_K = a - \delta - g - c$ in Figure 1b, could be negative for sufficiently large value of g . Even when the intercept is positive, the common steady state growth rate of capital, output and consumption can be negative, as shown in Figure 1b.

A balanced-budget increase in public consumption.

When there is a balanced-budget increase in public consumption, the capital growth line shifts down vertically by the increase in g (as shown in Figure 2a), and the consumption parabola shift up and to the left, reducing the long-run equilibrium value of c . As shown in Figure 2b, the effect on the long-run growth rate of capital is unambiguously negative: while the long-run consumption/capital ratio falls, it falls by less than the increase in the government consumption/capital ratio.

$$0 > \frac{dc_1^*}{dg} = -0.5 \left\{ 1 + \frac{\Upsilon}{[\Upsilon^2 + 4\eta\beta]^{0.5}} \right\} > -1$$

$$\Upsilon = \gamma^{-1}(a' - \delta - \rho) + n - a + \delta + g$$

This result, that an increase in public consumption crowds out capital formation as well as private consumption is different from the result that would have been obtained in the representative agent version of the model (the special case where $\beta = 0$). When $\beta = 0$, government consumption only crowds out

private consumption in the long run, leaving capital formation unchanged. More generally, in the representative agent model, any unanticipated, immediate permanent increase in public consumption causes an equal reduction in private consumption, in the short run as well as in the long run. Note from equation (37) that when $\beta = 0$, the \dot{c} equation is homogeneous. There is a trivial stationary solution ($c_2^* = 0$) and a sensible stationary solution ($c_1^* = -[\gamma^{-1}(a' - \delta - \rho) - \lambda - a + \delta + g]$ and $\mathcal{G}_{\mathcal{H}}^* = \gamma^{-1}(a' - \delta - \rho) - \lambda$). Note that since the interest rate (which equals the private rate of return to capital) and the time preference rate both are exogenous and constant, they will not in general be equal to each other. From equation (6c) the rate of growth of individual consumption will, in and out of steady state be equal to $\gamma^{-1}(a' - \delta - \rho)$.

Returning to the case with a positive birth rate, the transition to the new stationary equilibrium will be instantaneous if the increase in g is unanticipated and permanent. With K predetermined at the moment of the fiscal shock, the decline in c from c_1^{*0} to c_1^{*1} must be due to a fall in the level of consumption. Afterwards the rate of growth of aggregate consumption equals the new lower rate of growth of capital. If public spending is not intrinsically valued, this increase in public spending constitutes an unambiguous worsening of welfare.

If the announcement date of the increase in public consumption (t_0) precedes the implementation date (t_1), the behaviour over time of c and $\mathcal{G}_{\mathcal{H}}$ is as shown in Figure 3a,b. Starting from a stationary equilibrium at c_1^{*0} with a capital growth rate $\mathcal{G}_{\mathcal{H}}^0$, the level of consumption jumps to a lower level (a point such as Ω_1 in Figure 3a) immediately (at t_0) when the unexpected news about the future higher taxes associated with the future higher public spending arrives. Note that this initial decline in consumption

is smaller than when the policy change is immediate ($t_0 = t_1$). Between the announcement date (t_0) and the implementation date (t_1) the level of consumption per unit of capital moves continuously from Ω_1 to Ω_2 . At the implementation date t_1 , the level of c is at its new steady state value and its rate of change jumps from the negative value at Ω_2 to zero. The rate of growth of the capital increases at the announcement date from \mathcal{G}_K^0 to the value of \mathcal{G}_K at Ω_1 in Figure 3a. Between the announcement date and the implementation date \mathcal{G}_K continues to rise. At t_1 the system has reached point Ω_2 and the rate of growth of the capital stock declines to its new, lower long run equilibrium value.

An increase in the time preference rate.

For reasons of space I henceforth only consider unanticipated announcements of immediate permanent shocks. As shown in Figure 4a,b an increase in the pure rate of time preference leaves the capital growth line in Figure 4b unaffected while the consumption parabola in Figure 4a shifts down everywhere. With the unanticipated permanent shock, the transition to the new higher steady state level of consumption per unit of capital and lower steady state growth rate of capital is immediate. Greater impatience results in more consumption in the short run but less growth and consumption in the long run.²⁰

A higher birth rate.

As shown in Figure 5a,b an increase in β leaves the capital growth line unchanged and shifts the consumption parabola up.²¹ The new long-run equilibrium has a higher growth rate and a lower consumption-capital ratio.²² When the increase in the birth rate is unexpected, immediate and permanent, the transition to the new steady state is immediate.²³

A reduction in life expectancy.

Figure 4a,b can also serve (qualitatively) to illustrate the effects of an increase in λ , the instantaneous probability of death. As expected, shorter horizons boost the long-run consumption/capital ratio and reduce long-run growth.²⁴ The capital growth line does not shift and the consumption parabola shifts down.²⁵ If the reduction in life expectancy is unanticipated, immediate and permanent, the transition to the new steady state will be immediate.

Note that when the birth rate and the death rate increase by equal amounts, keeping the rate of growth of population constant, the model predicts a net reduction in the saving rate. Long-run consumption per unit of capital increases and the growth rate of the capital stock decreases:

$$\frac{\partial c_1^*}{\partial \beta} + \frac{\partial c_1^*}{\partial \lambda} = (\eta + \beta) \{ [\gamma^{-1}(a' - \delta - \rho) + n - a + \delta + g]^2 + 4\eta\beta \}^{-0.5}$$

An increase in the intertemporal elasticity of substitution.

It is obvious that the capital growth line is unaffected by the intertemporal elasticity of substitution $1/\gamma$. From equations (36) and (37) we obtain that:

$$\left. \frac{\partial c}{\partial \gamma} \right|_{c \text{ given}} = (\beta + c)(a' - \delta + \rho)$$

The consumption parabola will shift up (down) if the private return to capital $a' - \delta = r$ exceeds (is below) the subjective time preference rate ρ . From

equation (6c) we know that if $r > \rho$, individual consumption is low but rising. If less importance is attached to the smoothing of consumption over time ($1/\gamma$ increases), we should expect to move to an equilibrium with a lower level but a higher growth rate of consumption.²⁶ This is the case where the consumption parabola shifts up, as in Figure 5a. If the change is unanticipated and permanent, the transition to the new steady state with its lower value of c and its higher value of \dot{c}/c will be instantaneous.

Capital rental taxes.

A tax ζ_K on the rental income of capital (with the revenue returned as equal per capita lump-sum transfers to all those currently alive) changes the arbitrage condition equating the returns on bonds to the returns from owning capital to

$$r = f'(1) - \delta - \zeta_K = a' - \delta - \zeta_K$$

An increase in the capital income tax rate ζ_K is therefore equivalent in our model to a reduction in a' with a unchanged. The tax leaves the before-tax private marginal product of capital (and the social marginal product of capital) unchanged, and reduces the after-tax private rate of return to capital one-for-one. It is clear that an increase in ζ_K does not shift the capital growth line. Its effect on the consumption parabola is given by:

$$\left. \frac{\partial c}{\partial \zeta_K} \right|_{c \text{ given}} = \left(1 - \frac{1}{\gamma}\right)\beta - \frac{1}{\gamma}c$$

In the frequently analyzed logarithmic utility case ($\gamma = 1$) the consumption parabola shifts down, as in Figure 4a,b, raising long-run c and

reducing long-run \mathcal{G}_K . For this result to be reversed and the consumption parabola to shift up, it must be true that $\gamma^{-1} < \frac{\beta}{\beta + c}$.²⁷

An increase in the capital rental tax rate ζ_K does two things. First, it reduces the after-tax return to capital corresponding to any given pre-tax rate of return. Because of our linear technology the before-tax rate of return is fixed, so the after-tax rate of return and the rate of interest decline one-for-one with the increase in ζ_K . Second, it transforms capital income into lump-sum transfer payments to all those currently alive. By doing so it redistributes, at time t , some income from those born before time t , who own the capital and pay the capital income tax, to those born at time t , who own only their human capital plus the present discounted value of the net future lump-sum transfers they receive. In the representative agent special case of our model ($\beta = 0$), the redistribution effect is absent. There is just an (income-compensated) reduction in the rate of interest. The substitution effect of the lower rate of interest will shift down the consumption parabola, thus raising the long-run value of c and reducing the growth rate of capital. When β is positive, the newborn receive a bonus from the older generations when ζ_K increases. They do not own any capital on which to pay capital income tax. If the elasticity of intertemporal substitution $1/\gamma$ is small (less than 1), the (negative) income effect on current consumption of the lower interest rate they face as a result of the increase in ζ_K will dominate the substitution effect and they will save more. It is conceivable that this effect dominates the increase in consumption by the older generations. This is essentially the point made by Engel and Kletzer [1990] in the context of an open economy OLG model with tariff revenues redistributed as a residence-based wealth subsidy.

Considering taxes on interest income ζ_r does not add to the analysis, as

the marginal private and social products of capital are unaffected. The before-tax interest rate would rise to offset the interest tax and leave the after-tax rate of interest unchanged. The newborn too will face an unchanged rate of interest. Since they have the same marginal propensity to spend out of comprehensive wealth as the older generations, there will be no effect on aggregate consumption.

An unfunded social security retirement scheme.

To study the long-run growth effects of the unfunded social security retirement scheme discussed in Section IV, I set $\pi = g = 0$ and consider balanced budget schemes with $B \equiv 0$. I define:

$$\omega \equiv \Omega/K$$

From equations (15), (29b) and (31)

$$(39) \quad \omega(t) = \frac{\beta t_1 t_2}{\beta - t_2} \int_t^{\infty} \frac{K(v)}{K(t)} e^{-(a' - \delta + \beta - t_2)(v-t)} dv$$

Note that the scale variable in the tax function, ϵ , is given by $\epsilon = K/L$.

The equations of motion and the capital growth equation for this case are given in equations (40) through (42).

$$(40) \quad \dot{c} = -\eta\beta + [\gamma^{-1}(a' - \delta - \rho) + n - a + \delta]c + c^2 + \eta\omega$$

$$(41) \quad \dot{\omega} = (a' - a + \beta - t_2 - c)\omega - t_1 t_2 \left(\frac{\beta}{\beta - t_2} \right)$$

$$(42) \quad \mathcal{G}_{\mathcal{H}} = a - \delta - c$$

Note that the forward-looking integral in equation (39) exists only if $r + \beta - t_2$ exceeds the growth rate of capital $\mathcal{G}_{\mathcal{K}}$ in steady state. Also, ω cannot change sign for given t_1 and t_2 . In what follows I only consider small changes in t_1 and t_2 that do not change their signs. For reasons of space, I shall look only at the case where both t_1 and t_2 are positive, which implies that ω is always positive.

The $\dot{\omega} = 0$ locus is given by

$$(43) \quad c = a' - a + \beta - t_2 - t_1 t_2 \left(\frac{\beta}{\beta - t_2} \right) \omega^{-1} \quad c \geq 0$$

This is the truncated (for $c \geq 0$ and $\omega > 0$) rectangular hyperbola shown in Figure 6a through 6d. Its vertical asymptote is the vertical axis ($\omega = 0$) and its horizontal asymptote is $a' - a + \beta - t_2$. There is no solution to this equation for positive values of both c and ω unless $a' - a + \beta - t_2 > 0$. I assume this to be the case in Figures 6a through 6d and 7.

The $\dot{c} = 0$ locus is the "parabola on its side", shown in Figures 6a through 6d and in Figure 7, given by

$$(44) \quad c^2 + [\gamma^{-1}(a' - \delta - \rho) + n - a + \delta]c + \eta(\omega - \beta) = 0.$$

On this locus, when $c = 0$, $\omega = \beta$. To obtain real solutions for c , we require $\omega \leq \beta + [\gamma^{-1}(a' - \delta - \rho) + n - a + \delta]^2 / 4\eta$.

When $\omega = \beta + [\gamma^{-1}(a' - \delta - \rho) + n - a + \delta]^2 / 4\eta$, $c = -\frac{1}{2}[\gamma^{-1}(a' - \delta - \rho) + n - a + \delta]$.

Unless $\beta + [\gamma^{-1}(a' - \delta - \rho) + n - a + \delta]^2/4\eta \geq \frac{t_1 t_2}{(\beta - t_2)(a' - a + \beta - t_2)}$, no stationary solution with positive values for c and b exists. This case is shown in Figure 6d. In the rest of this subsection I assume this condition is satisfied, so one or two stationary solutions with positive values for both w and c exist. From equation (44) the two solutions for c are given by

$$c = \frac{1}{2} \left[-[\gamma^{-1}(a' - \delta - \rho) + n - a + \delta] \pm \{[\gamma^{-1}(a' - \delta - \rho) + n - a + \delta]^2 - 4\eta(\omega - \beta)\}^{\frac{1}{2}} \right]$$

The long run effect on c and w of an increase in t_1 with t_2 adjusting according to equation (25) so as to maintain total tax receipts unchanged, yields:

$$(45a) \quad \left. \frac{dc}{dt_1} \right|_{dT=0} = \Delta^{-1} \left[\frac{\beta - t_2}{t_1} + \frac{\beta}{w} \right] \eta$$

$$(45b) \quad \left. \frac{d\omega}{dt_1} \right|_{dT=0} = -(\pm) \Delta^{-1} \left[\frac{\beta - t_2}{t_1} + \frac{\beta}{w} \right] \{[\gamma^{-1}(a' - \delta - \rho) + n - a + \delta]^2 - 4\eta(\omega - \beta)\}^{\frac{1}{2}}$$

$$(45c) \quad \Delta = \eta + (\pm) \frac{t_1 t_2 \beta}{(\beta - t_2) \omega^2} \{[\gamma^{-1}(a' - \delta - \rho) + n - a + \delta]^2 - 4\eta(\omega - \beta)\}^{\frac{1}{2}}$$

At a stationary equilibrium (c^*, ω^*) , the non-linear equations of motion can be approximated by the following system of linear differential equations with constant coefficients:

$$(46) \begin{bmatrix} \dot{c} \\ \dot{\omega} \end{bmatrix} = \begin{bmatrix} (\pm) \{ [\gamma^{-1} (a' - \delta - \rho) + n - a + \delta]^2 - 4\eta(\omega - \beta) \}^{\frac{1}{2}} & \eta \\ -\omega & \frac{t_1 t_2 \beta}{\omega(\beta - t_2)} \end{bmatrix} \begin{bmatrix} c - c^* \\ \omega - \omega^* \end{bmatrix}$$

Since both state variables, c and ω , are non-predetermined, a unique stationary equilibrium which is unstable would guarantee a unique continuously convergent solution. Such a configuration is shown in Figure 6a. Note that Δ is the determinant of the coefficient matrix on the right-hand side of equation (46). If the configuration of the stationary equilibrium is locally completely unstable, then Δ will be positive. When the stationary equilibrium is on the downward-sloping segment of the $\dot{c} = 0$ locus, (as at Ω in Figures 6a) is is always completely unstable. When the stationary equilibrium is on the upward-sloping part of the $\dot{c} = 0$ locus, it can still be completely unstable, provided that the $\dot{c} = 0$ locus has a steeper slope than the $\dot{\omega} = 0$ locus. Equilibria such as Ω in Figure 6b and Ω_1 in Figure 6c fall in this category. A stationary equilibrium such as Ω_2 in Figure 6c, where the positive slope of the $\dot{c} = 0$ locus is less than the slope of the $\dot{\omega} = 0$ locus corresponds to a negative value of Δ . The equilibrium is a saddlepoint, and there is a (one-dimensional) continuum of initial conditions from which the system will converge to that stationary equilibrium.

When Δ is positive, one sees from equation (45a) that the new stationary equilibrium value of c increases when t_1 is increased and t_2 reduced in a balanced-budget manner (when there is an increase in the size of the unfunded social security retirement scheme). Graphically, the $\dot{\omega}$ locus shifts up when t_1 is increased and t_2 reduced with total taxes receipts constant. Figure 7

shows how, when the equilibrium is a completely unstable one on the downward-sloping segment of the $\dot{c} = 0$ locus, w decreases across steady states as c increases. When the completely unstable equilibrium lies on the upward-sloping segment of the $\dot{c} = 0$ locus (as at Ω in Figure 6b or Ω_1 in Figure 6c) the increase in the scale of the unfunded social security retirement scheme increases w along with c .²⁸

When the stationary equilibrium is unique and completely unstable, the transition to the new steady state following an unexpected, immediate and permanent increase in the scale of the unfunded social security retirement scheme will be instantaneous.

Finally, from the capital growth equation we again note that, as always except for the case where exhaustive public spending is raised, the decline in the growth rate of capital equals the increase in c .

Deficit financing of a tax cut

The last case I consider will be the debt financing of a temporary cut in lump-sum taxes. For simplicity I again set $\pi = t_1 = t_t = 0$. The public spending/capital ratio g is also set equal to zero. There now are two state variables, c and b , whose behavior is governed by equations (47) and (48).

$$(47) \quad \dot{c} = -\eta\beta(1 + b) + [\gamma^{-1}(a' - \delta - \rho) + n - a + \delta]c + c^2$$

$$(48) \quad \dot{b} = (a' - a + c)b - \tau$$

Note that, with τ exogenous, the possibility of unstable public debt dynamics is built into the model. Since $a' < a$, a larger value of the level of the public debt/capital ratio, b , will be associated with a larger negative

rate of change of the public debt/capital ratio, \dot{b} , for small values of c (that is for large values of \mathcal{G}_H). For large values of c (for low or negative values of \mathcal{G}_H), however, larger values of b are associated with larger positive values of \dot{b} . Clearly, with τ exogenous, instability is in the air.²⁹

For illustrative purposes I consider a tax function that always causes the public-debt/capital ratio to converge to a unique stationary equilibrium value. It is given in equation (49).

$$(49) \quad \tau = \tau_0 + cb$$

In addition to the exogenous component τ_0 (assumed constant), there is an endogenous component which exactly offsets the term cb in equation (48). With this tax function, the debt dynamics are now governed by:

$$(50) \quad \dot{b} = (a' - a)b - \tau_0$$

Since the constant private marginal product of capital a' is always less than the private (and public) average product of capital a , b always converges monotonically to its long-run equilibrium value b^* given by

$$(51) \quad b^* = (a' - a)^{-1} \tau_0$$

The $\dot{c} = 0$ locus is unaffected by the nature of the fiscal rule. It is given by the non-negative solutions to

$$c^2 + [\gamma^{-1}(a' - \delta - \rho) + n - a + \delta]c - \eta\beta(1 + b) = 0$$

In ω, c space, this is again a parabola "on its side". Economically the only interesting case is where $b \geq -1$. Since $K \geq 0$, $b = -1$ implies $B = -K \leq 0$. The total value of all productive resources in this economy is K . When $B = -K$, the government (as net lender to the private sector) effectively owns the entire stock of productive resources in the economy. The government clearly cannot lend more than that in this closed system, as there are no remaining private resources against which these loans can be secured. With $b \geq -1$, there is one positive stationary solution given by

$$(52) \quad c = \frac{1}{2} \left[-[\gamma^{-1}(a' - \delta - \rho) + n - a + \delta] + \{ [\gamma^{-1}(a' - \delta - \rho) + n - a + \delta]^2 + 4\eta\beta(1 + b) \}^{\frac{1}{2}} \right]$$

In b - c space, the $\dot{c} = 0$ locus, shown in Figure 8, starts at $b = -1$ and $c = 0$. For $b > -1$, c increases monotonically with b , but at a decreasing rate. In the limit as b goes to infinity, the slope of the locus goes to zero.

The $\dot{b} = 0$ locus is vertical in b - c space. Since we only consider values of b greater than -1 , it follows from equation (51) that we require

$$\tau_0 < a - a'$$

If this restriction is satisfied, there will be a unique stationary equilibrium, Ω , in Figure 8. Locally, the system near Ω is a saddlepoint. Since there is one predetermined state variable b and one non-predetermined state variable c , this means that there will only be one continuously convergent solution. For a given value of τ_0 , SS is the unique convergent

saddlepath. The "most divergent" solution trajectory UU coincides with the $\dot{b} = 0$ curve. All solution trajectories other than SS will have an asymptote at UU (even though this may take them into the infeasible $c < 0$ region).

Figure 9a,b shows the response of c , b and \mathcal{G}_K , the growth rate of the capital stock, to an unanticipated permanent reduction in τ_0 . Since government exhaustive spending is unchanged, all this amounts to, (as can be seen from the government intertemporal budget constraint given in equation (20)), is a postponement of taxes that are constant in present discounted value (using the real interest rate r as the discount rate). Because the private sector effectively discounts at $r + \beta$ (since new tax payers will be born who will share part of the burden of the postponed taxes), this intertemporal redistribution of taxation is also an intergenerational redistribution of taxation that leaves those currently alive better off.

Starting from an initial stationary equilibrium at Ω in Figure 9b, the level of consumption immediately increases to Ω_{01} , the point on $S'S'$, the convergent saddlepath through the new long-run equilibrium Ω' , that lies vertically above Ω in Figure 9b. In Figure 7a this corresponds to a discontinuous reduction in the growth rate of capital and output, from Ω to Ω_{01} . After the initial jump-increase in consumption, the consumption/capital ratio and the debt/capital ratio increase continuously along the convergent saddlepath $S'S'$ towards their new long-run equilibrium values at Ω' . The capital growth rate declines continuously from Ω_{01} in Figure 9a to Ω' . This confirms the results obtained by Alogoskoufis and van der Ploeg [1990a,b].

As demonstrated in Saint-Paul [1990], alternative consumption trajectories supported by different intertemporal redistributions of taxation cannot be Pareto-ranked. Government borrowing, with debt serviced through

lump-sum taxation (or balanced-budget redistribution schemes using lump-sum taxes and transfers such as the unfunded social security retirement scheme analyzed earlier) merely redistributes intergenerationally. Postponing taxation by borrowing favors current over future generations, but there are no efficiency issues involved. This may seem surprising, since we are in a second-best world: the private return on capital $a' - \delta$ is below the social return $a - \delta$. This inefficiency, however, is not affected in any way by the intergenerational redistribution effected by the government through borrowing or through unfunded social security retirement schemes.

(VII) Conclusion.

If the production technology of the economy (broadly defined) permits endogenous growth, one obvious lesson is that fiscal policy changes and changes in the parameters that govern private behavior can have long-run *growth rate* effects as well as long-run *level* effects. The welfare implications of this "magnification" of the effects of exogenous shocks on the growth rate are not as straightforward as the positive implications. As was pointed out by Saint-Paul [1990], balanced-budget redistribution towards the old and deficit financing of tax cuts (even age-independent tax cuts) will reduce the long-run growth rates of capital, output and consumption. As long as the taxes involved are lump-sum, however, the trajectory with the lower growth rate will not be Pareto-dominated by that with the higher growth rate. There is intergenerational redistribution, from the future generations towards the present ones, but no free lunches are being served or taken away.

Against that, of course, it should be pointed out that the magnitude of the intergenerational redistribution associated with a given policy change is enhanced in endogenous growth models. Reasonable social welfare functions may

suggest policies more favorable to a higher savings rate, if the returns to saving and accumulation are bounded away from zero sufficiently strongly to permit endogenous growth. In any case, even if the efficiency consequences of policy are not magnified, the distributional consequences will be. Policy is therefore likely to matter more in endogenous growth models than in exogenous growth models.

A second lesson emerges as a by-product of one of the less attractive features of the one-sector endogenous growth model used in this paper: the constancy of the real interest rate. In this model, as in the "Unpleasant Monetarist Arithmetic" model of Sargent and Wallace [1984], there is financial crowding out: government borrowing reduces total national saving and, in a closed economy, displaces private capital formation. So does an increase in the scale of the social security retirement scheme. Still, there is no movement of interest rates in response to the policy changes (or changes in private behavior) that cause the financial crowding out. In the world of our model, those who view financial crowding out as mediated necessarily through higher real interest rates would fail to identify the effect of government financing on private capital formation.

A third lesson is mainly for educators: the analysis of the response of economic growth to a variety of private or government shocks is considerably more straightforward when the economy is represented by the simplest endogenous growth model than when it is represented by the simplest exogenous growth model.

REFERENCES

- Alogoskoufis, George S. and Frederick van der Ploeg [1990a], "Endogenous Growth and Overlapping Generations", Birkbeck College, University of London, Discussion Paper in Economics, 26/90, November.
- _____ and _____ [1990b], "On budgetary policies and economic growth", Centre for Economic Research Discussion Paper, No. 496, December.
- _____ and _____ [1991], "On budgetary policies, growth and external deficits in an interdependent world", Paper Presented at the NBER/CEPR/TCER Conference on Fiscal Policies in Open Macro Economies, January, Tokyo.
- Barro, Robert J. [1990], "Government Spending in a Simple Model of Endogenous Growth", *Journal of Political Economy*, 98, October.
- _____ and Xavier Sala-i-Martin [1990], "Public Finance in Models of Economic Growth", NBER Working Paper No. 3362, May.
- Bernanke, B and M. Gertler [1987], "Banking and Macroeconomic Equilibrium", in W. A. Barnett and K. Singleton, eds., *New Approaches to Monetary Economics*, Cambridge University Press, Cambridge, pp. 89-111.
- Blanchard, Olivier J. [1985], "Debt, Deficits and Finite Horizons", *Journal of Political Economy*, 93, No.2, April, pp. 223-247.
- Buiter, Willem H. [1988], "Death, birth, productivity growth and debt neutrality", *Economic Journal*, 98, June, pp. 279-293, also in Willem H. Buiter, *Macroeconomic theory and stabilization policy*, Manchester University Press, Manchester, 1989, pp. 315-331..
- _____ [1989], "Debt neutrality, professor Vickrey and Henry George's 'single tax'", *Economics Letters*, 29, pp. 43-47, also in Willem H. Buiter, *Principles of Budgetary and Financial Policy*, MIT Press, 1990.
- _____ [1990], "Debt neutrality, Redistribution and consumer heterogeneity", in W. H. Buiter, *Principles of Budgetary and Financial Policy*, MIT Press, 1990, also in *Essays in Honor of James Tobin*, W.C. Brainard et. al. eds., MIT Press, forthcoming.
- _____ and Kenneth M. Kletzer [1991a], "Persistent differences in national productivity growth rates with a common technology and free capital mobility", forthcoming in the *Journal of Japanese and International Economics*.
- _____ and _____ [1991b]. "Persistent Productivity Growth Differentials and Nontraded Growth Inputs", Yale University mimeo, June.

- _____ and _____ [1991c], "Fiscal Policies and Productivity Growth in an Interdependent World Economy", Yale University mimeo, April.
- Engel, Charles M. and Kenneth M. Kletzer [1990], "Tariffs and saving in a model with new generations", **Journal of International Economics**, February.
- Grossman, Gene M. and Elhanan Helpman [1991], **Innovation and Growth in the Global Economy**, MIT Press, Cambridge, MA.
- Helpman, Elhanan [1991], "Endogenous Macroeconomic Growth Theory", Mimeo, Tel Aviv University, August.
- Jones, Larry E. and Rodolfo Manuelli [1990], "Finite Lifetimes and Growth", NBER Working Paper No. 3469.
- Lucas, Robert E. Jr. [1988], "On the Mechanics of Economic Development", **Journal of Monetary Economics**, 22, pp. 3-42.
- Romer, Paul [1986], "Increasing Returns and Long-Run Growth", **Journal of Political Economy**, 94, pp. 1002-1037.
- _____ [1990], "Endogenous Technological Change", **Journal of Political Economy**, 98, pp. S71-S102.
- Saint-Paul, Gilles [1990], "Fiscal Policy in an Endogenous Growth Model", CNRS-ENS-EHSS Document No. 91-04.
- Sala-i-Martin, Xavier [1990a], "Lecture Notes on Economic Growth: Introduction to the Literature and Neoclassical Models, Volume I", Economic Growth Center Discussion Paper No. 621, December.
- _____ [1990b], "Lecture Notes on Economic Growth: Five Prototype Models of Endogenous Growth, Volume II, Economic Growth Center Discussion Paper No. 622, December.
- Sargent T.J. and Neil Wallace [1984], "Some Unpleasant Monetarist Arithmetic", in B. Griffith and G.E. Wood eds., **Monetarism in the United Kingdom**, pp. 15-41, London, Macmillan.
- Sheshinski, Eitan [1967], "Optimal Accumulation with Learning by Doing", in Karl Shell, ed. **Essays on the Theory of Optimal Economic Growth**, MIT Press, Cambridge, MA.
- Solow, Robert M. [1957], "Technical Change and the Aggregate Production Function", **Review of Economics and Statistics**, 39, pp. 312-320.
- Weil, P. [1990], "Overlapping families of infinitely-lived agents", **Journal of Public Economics**.

Footnotes

¹In the standard expected utility framework with a time-separable utility function, the precautionary saving motive is governed by the third derivative of the instantaneous utility function.

²Note, however, that the existence of permanent effects on the growth rates of capital, output and consumption does not automatically imply the existence of large efficiency effects. In Section VI we shall see examples where public policy permanently affects the growth rate, but the alternative growth paths cannot be Pareto-ranked. There will be large welfare effects, but these take the form of intergenerational redistributions of welfare.

³In the finite-horizon OLG model of Samuelson and Diamond, this specification of technology and property rights means that the problem flagged by Jones and Manuelli [1990], that the value of the endowment of the young may not keep up with the value of the capital owned by the old (which the young are supposed to purchase from the old in equilibrium), will not occur. A richer specification of technology and property rights that achieves the same purpose was used by Buiter and Kletzer [1991a,b]. In the age-independent time horizon OLG model of the current paper, the life-cycle issues emphasized by Jones and Manuelli are absent. The problem of ensuring that the new generations are endowed with scarce resources whose value can grow at an endogenously determined rate remains, however.

⁴ $\gamma = 1$ corresponds to the case of log utility.

⁵The only uncertainty modeled explicitly is the uncertainty concerning the time of one's demise. Consumers born at time s are assumed to know that the probability of surviving till time $t \geq s$ is $e^{-\lambda(t-s)}$. This term augments the subjective discount factor, which becomes $e^{-(\rho+\lambda)(v-t)}$ for someone discounting, at time t , the utility of consuming at time $v \geq t$. The model can then be treated as a perfect foresight model.

⁶Note that $\dot{\eta} = \eta\{\eta - [(\frac{\gamma-1}{\gamma})r + \lambda + \frac{1}{\gamma\rho}]\}$. In steady state this gives a non-zero solution $\eta = (\frac{\gamma-1}{\gamma})r + \lambda + \frac{1}{\gamma\rho}$. In the logarithmic utility case ($\gamma = 1$) this reduces to $\eta = \rho + \lambda$, both in and out of steady state.

⁷The absence of involuntary or unintended bequests is due to the assumption of perfect annuities markets.

⁸Government capital formation is not considered. Public consumption either is intrinsically useless or, if useful, enters the private utility function in an additively separable manner.

⁹We shall also consider the effects of changes in G and B .

¹⁰Saint-Paul considers a "twisting" of the wage-age profile, that is a larger value of π combined with a higher value of the starting wage at age zero. What we do in this paper is equivalent in terms of its impact effect on the savings rate.

¹¹Note that ϵ is also the scale factor applied to the tax function given in equation (9). This permits a well-behaved steady-state to exist in the model but has no other significance.

¹²Sheshinski [1967] actually suggested using the economy-wide stock of physical capital as the index of labor efficiency, not the economy-wide capital-labor ratio. Using this alternative specification would of course generate a model with unbounded static increasing returns to scale, something we do not wish to contemplate even at this level of abstraction. Romer [1986] and Lucas [1988] developed models with increasing static returns to scale in which the quality of labor is augmented not by the accumulation of physical capital but rather by accumulation of knowledge and skills.

¹³The private marginal product of capital is $a' - \delta$ and the social marginal product of capital $a - \delta$. The private marginal product of labor is $a - a'$, its social marginal product is zero.

¹⁴Unless the government transfers resources to them, by making $\bar{\theta}(t,t)$ positive.

¹⁵One way to endow the newborn with capital at birth is for the government to make a capital transfer to them or for the government to commit itself credibly to a future sequence of current transfer payments.

¹⁶An attractive feature of this model is that it does not imply a constant real interest rate.

¹⁷Note, however, that it is not Pareto efficient because of the capital stock (or labor) externality.

¹⁸We owe this point to Olivier Blanchard. It is spelled out formally in Saint-Paul [1990].

¹⁹Note that while the ratio of aggregate taxes on labor income to the aggregate capital stock varies endogenously, each individual private agent takes the amount he pays in taxes on labor income to be independent of his individual accumulation of capital. The tax therefore remains a lump-sum tax on labor income and does not become a capital income tax.

$$^{20}\frac{\partial c_1^*}{\partial \rho} = 0.5\gamma^{-1}\left\{1 - \frac{[\gamma^{-1}(a' - \delta - \rho) + n - a + \delta + g - 2\beta]}{\{[\gamma^{-1}(a' - \delta - \rho) + n - a + \delta + g]^2 + 4\eta\beta\}^{0.5}}\right\} > 0$$

²¹From equation (37) we obtain that $\left.\frac{\partial c}{\partial \beta}\right|_{c \text{ given}} = -\eta + c$. From the aggregate consumption function we know that $C = \eta(A + H - \Theta)$. Since $A = K$ in our case we have $c = \eta\left(1 + \frac{H - \Theta}{K}\right)$. If human capital net of the present discounted value of taxes on human capital is non-negative, then $c > \eta$. We assume this condition to hold.

$$^{22}\frac{\partial c_1^*}{\partial \beta} = 0.5\left\{-1 + \frac{[\gamma^{-1}(a' - \delta - \rho) + n - a + \delta + g + 2\eta]}{\{[\gamma^{-1}(a' - \delta - \rho) + n - a + \delta + g]^2 + 4\eta\beta\}^{0.5}}\right\}$$

$(\eta - c)\{[\gamma^{-1}(a' - \delta - \rho) + n - a + \delta + g]^2 + 4\eta\beta\}^{-0.5} < 0$ provided human capital is positive.

²³An increase in the rate at which labor power decays with age, π , has exactly the same effect on c as an increase in the birth rate.

$$\begin{aligned} {}^{24}\frac{\partial c_1^*}{\partial \lambda} &= 0.5 \left\{ 1 + \frac{-[\gamma^{-1}(a' - \delta - \rho) + n - a + \delta + g - 2\beta]}{\{[\gamma^{-1}(a' - \delta - \rho) + n - a + \delta + g]^2 + 4\eta\beta\}^{0.5}} \right\} \\ &= (c + \beta) \{[\gamma^{-1}(a' - \delta - \rho) + n - a + \delta + g]^2 + 4\eta\beta\}^{-0.5} > 0. \end{aligned}$$

²⁵From equation (37) it follows that $\left. \frac{\partial c}{\partial \lambda} \right|_{c \text{ given}} \equiv -(\beta + c) < 0$.

$${}^{26}\frac{\partial c_1^*}{\partial \beta} = (c + \beta)(a' - \delta - \rho) \{[\gamma^{-1}(a' - \delta - \rho) + n - a + \delta + g]^2 + 4\eta\beta\}^{-0.5}.$$

²⁷Let the consumption/output ratio be 0.8 and the annual capital-output ratio 3.3. This means that $c = 0.24$. With $\beta = 0.01$, the intertemporal elasticity of substitution would have to be less than 0.04 for the consumption parabola to shift up instead of down as the capital income tax rate increases. Those who pretend to know about these things, argue that this is too low a number. Halving or doubling the birth rate doesn't change that conclusion.

²⁸Note that when Δ is negative, as at Ω_2 in Figure 8d, the increase in the scale of the social security retirement scheme reduces c and w .

²⁹Even with τ exogenous, the model is not necessarily badly behaved everywhere. There can e.g. be a stationary equilibrium with a relatively small value of c and a negative value of b that constitutes, locally, a

saddlepoint. The $\dot{b} = 0$ locus in c - b space is a rectangular hyperbola with equation $c = a - a' + b^{-1}\tau$. Note that $c \geq 0$ is equivalent to $\frac{\tau}{b} \geq a' - a < 0$.

Negative values of b are therefore certainly not ruled out. In the following Figures A and B some possible configurations are shown. Figure A is for a positive value of τ . There always is a high c stationary equilibrium, with a positive value of b , Ω_1 , that is completely unstable. There may also be a low c equilibrium with a negative value of b , Ω_2 , that is a saddlepoint. This will occur if $\frac{\tau}{a' - a} > -1$. A higher value of τ will raise the value of c

(lower the value of \dot{K}/K) at the high c equilibrium (Ω_1) by shifting up the positive segment of the $\dot{b} = 0$ schedule. It will lower the value of c (raise \dot{K}/K) at the the low c equilibrium (Ω_2) by shifting down the negative segment

of the $\dot{b} = 0$ schedule. In Figure B, τ is negative. As shown in the Figure, there may be no stationary equilibrium with a positive value of c . If there are two equilibria (not shown), they will both have the same sign for b . All this is sufficiently bizarre not to devote more time to it.

Figure 1a

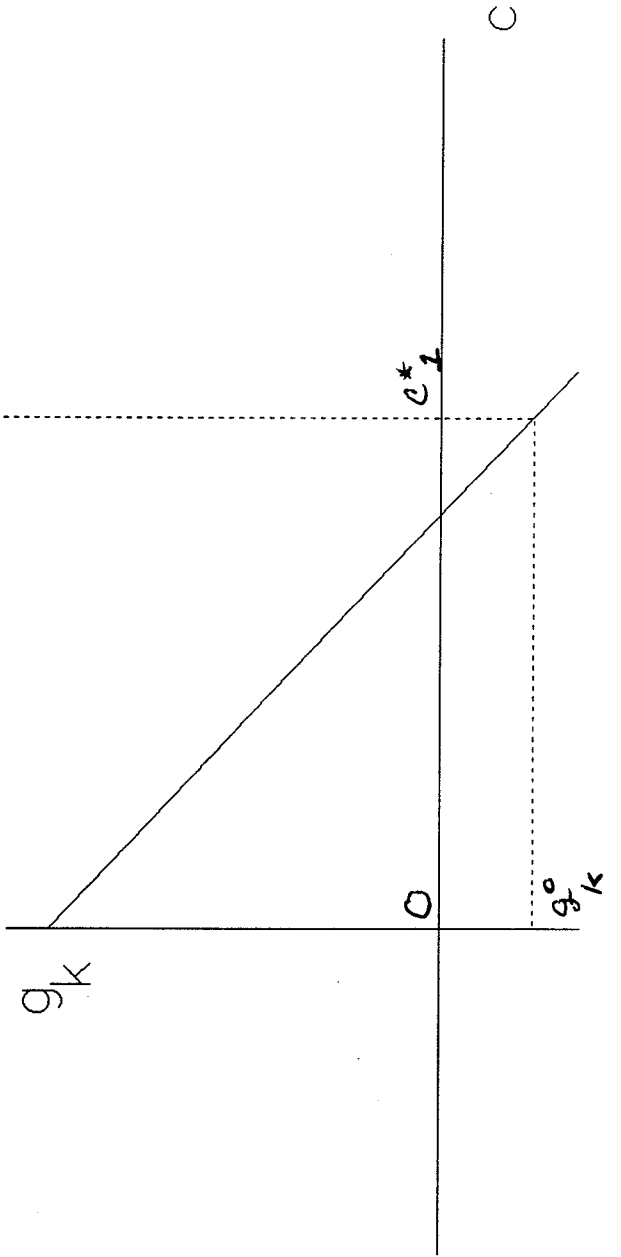
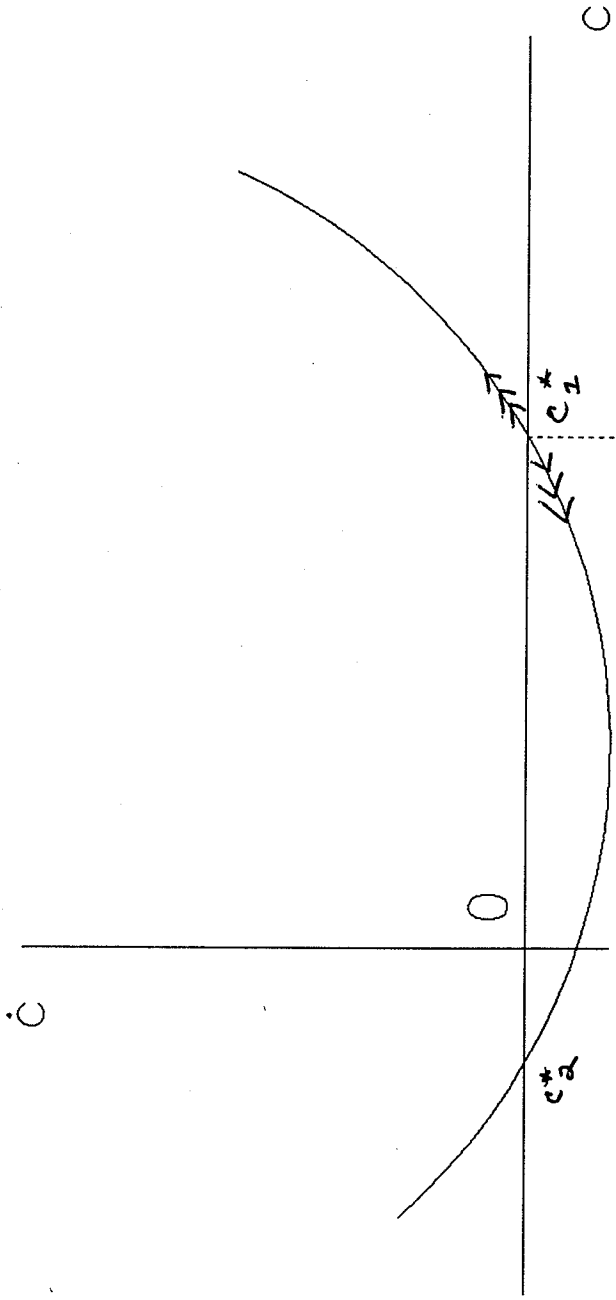

Figure 1b

Figure 2a

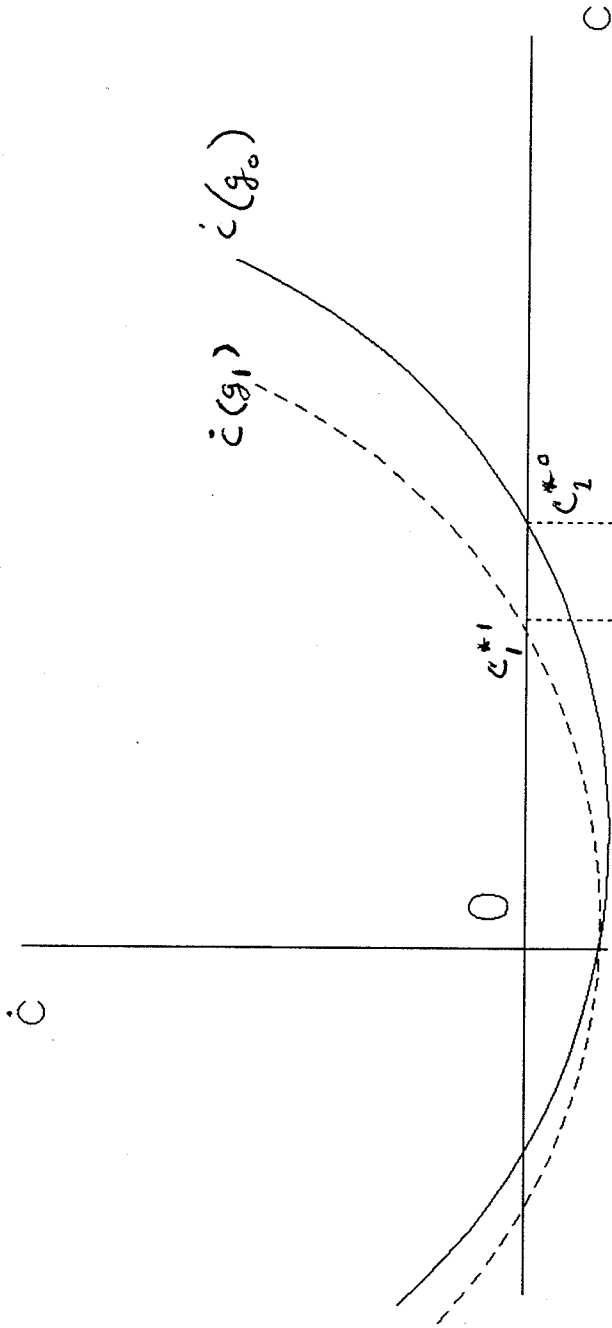

Figure 2b

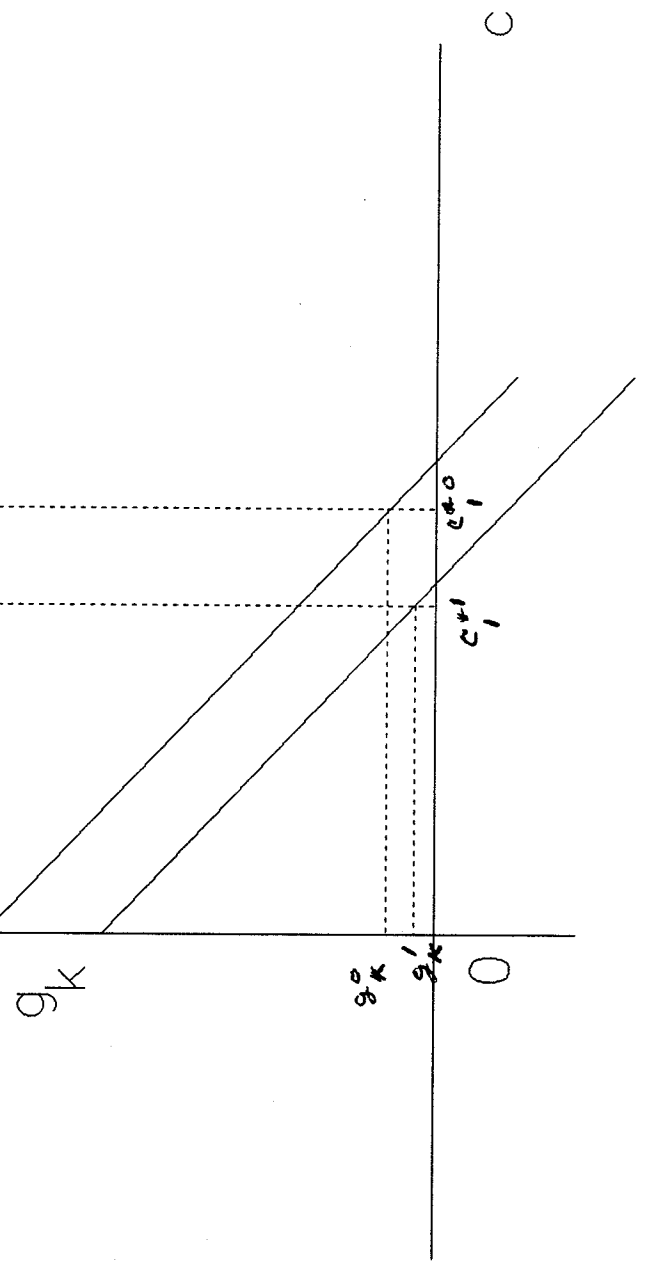

Figure 3a

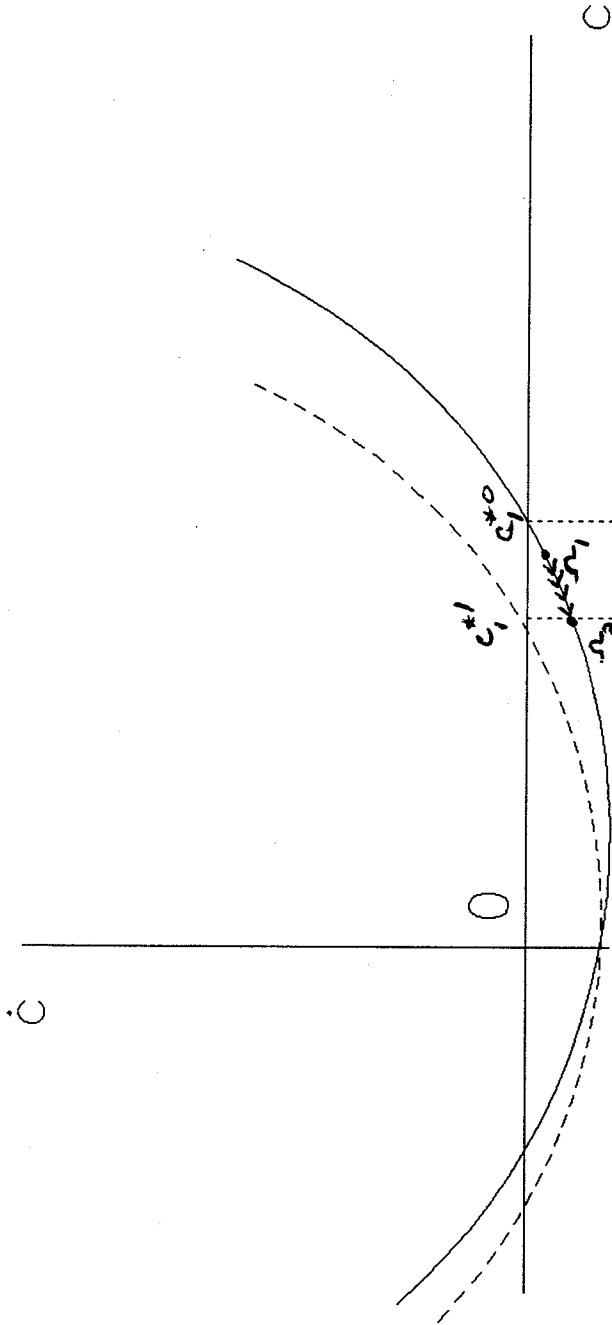

Figure 3b

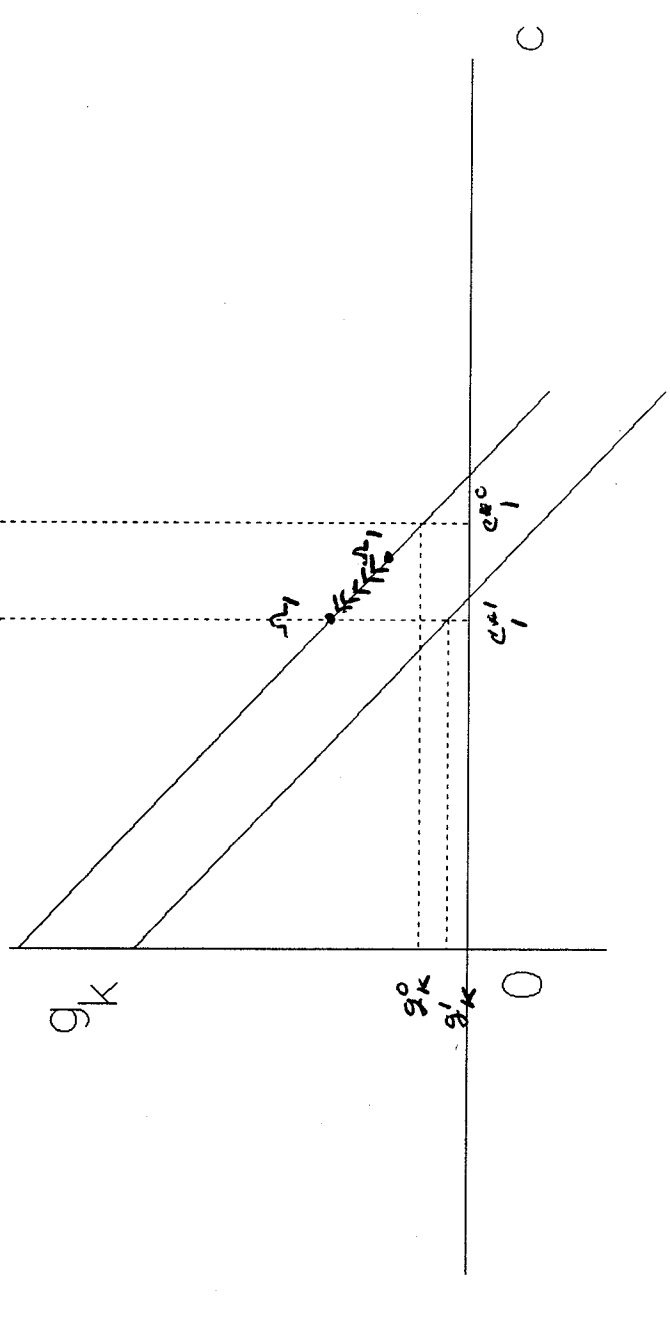

Figure 4a

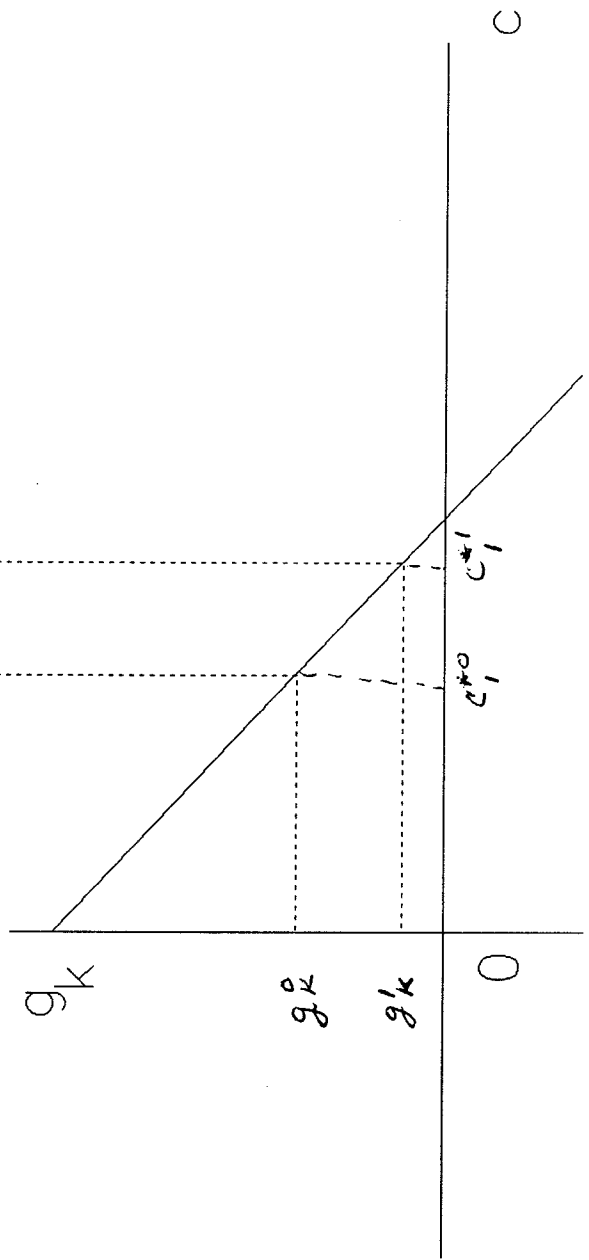
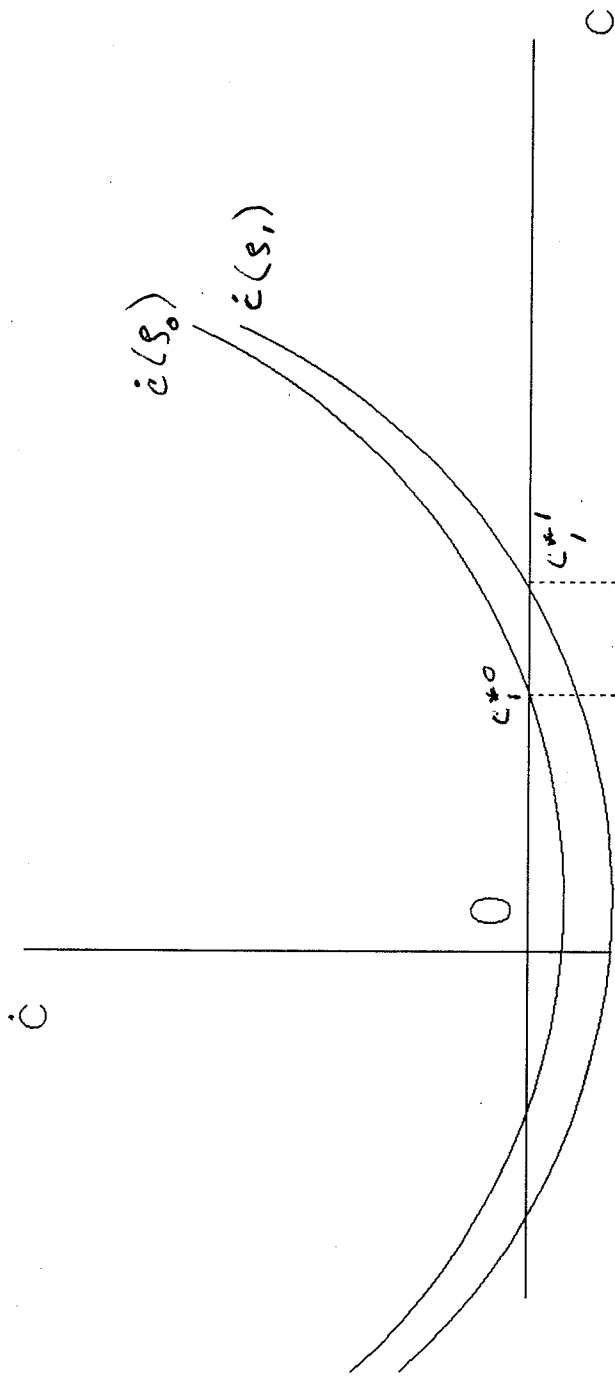

Figure 4b

Figure 5a

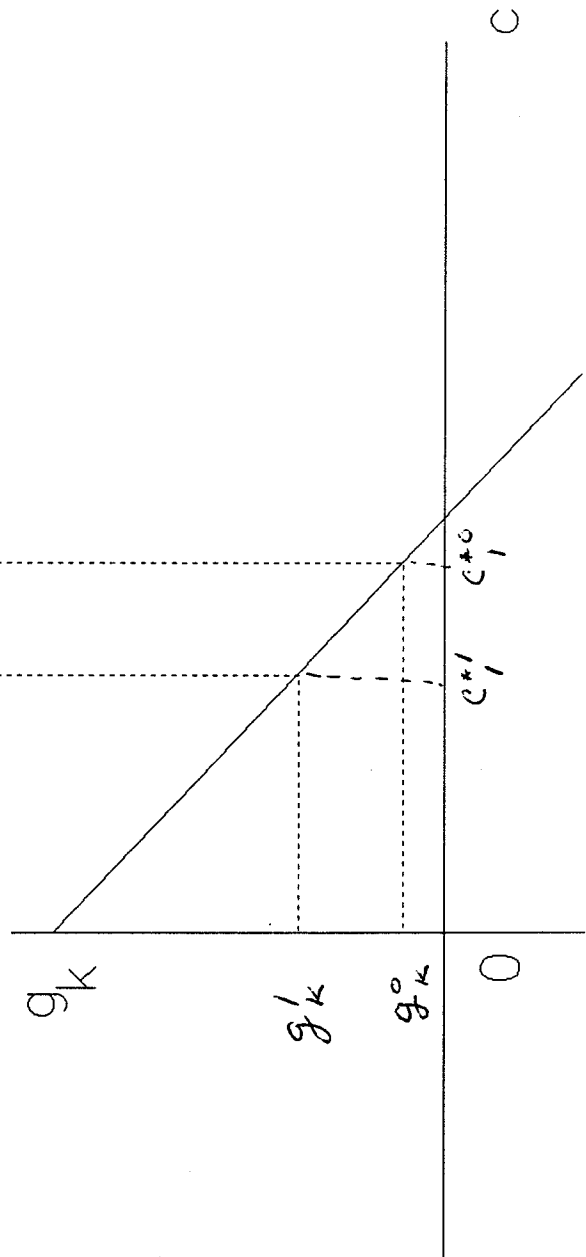
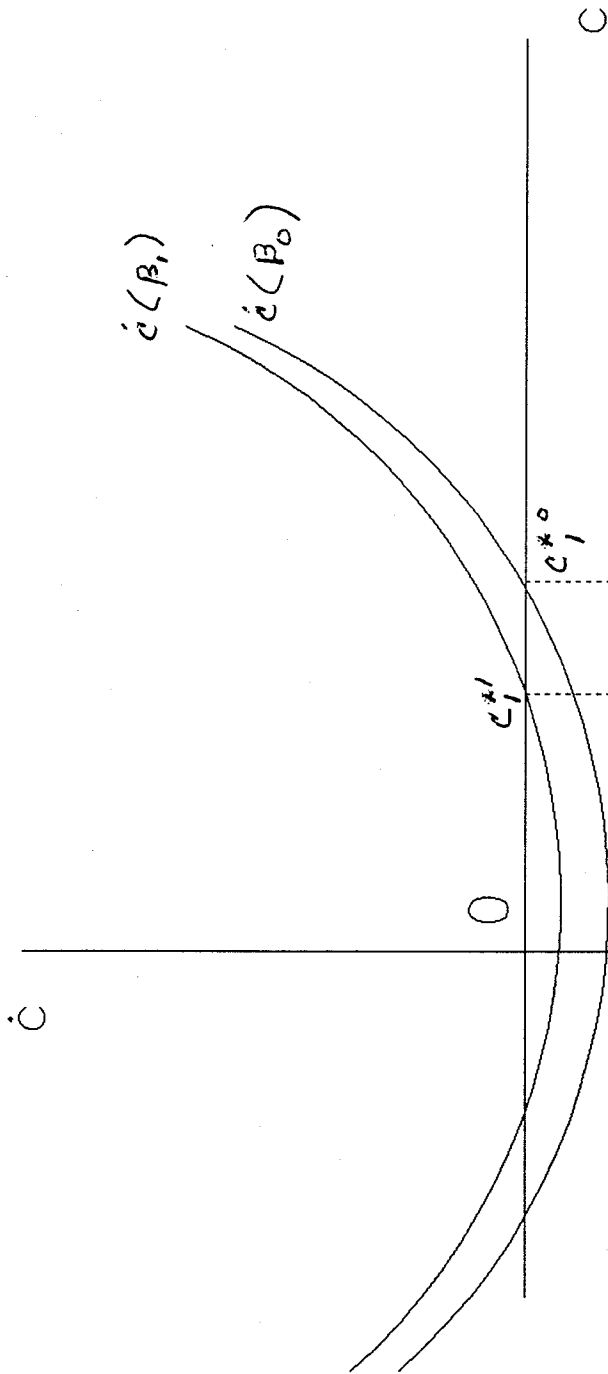

Figure 5b

Figure 6a

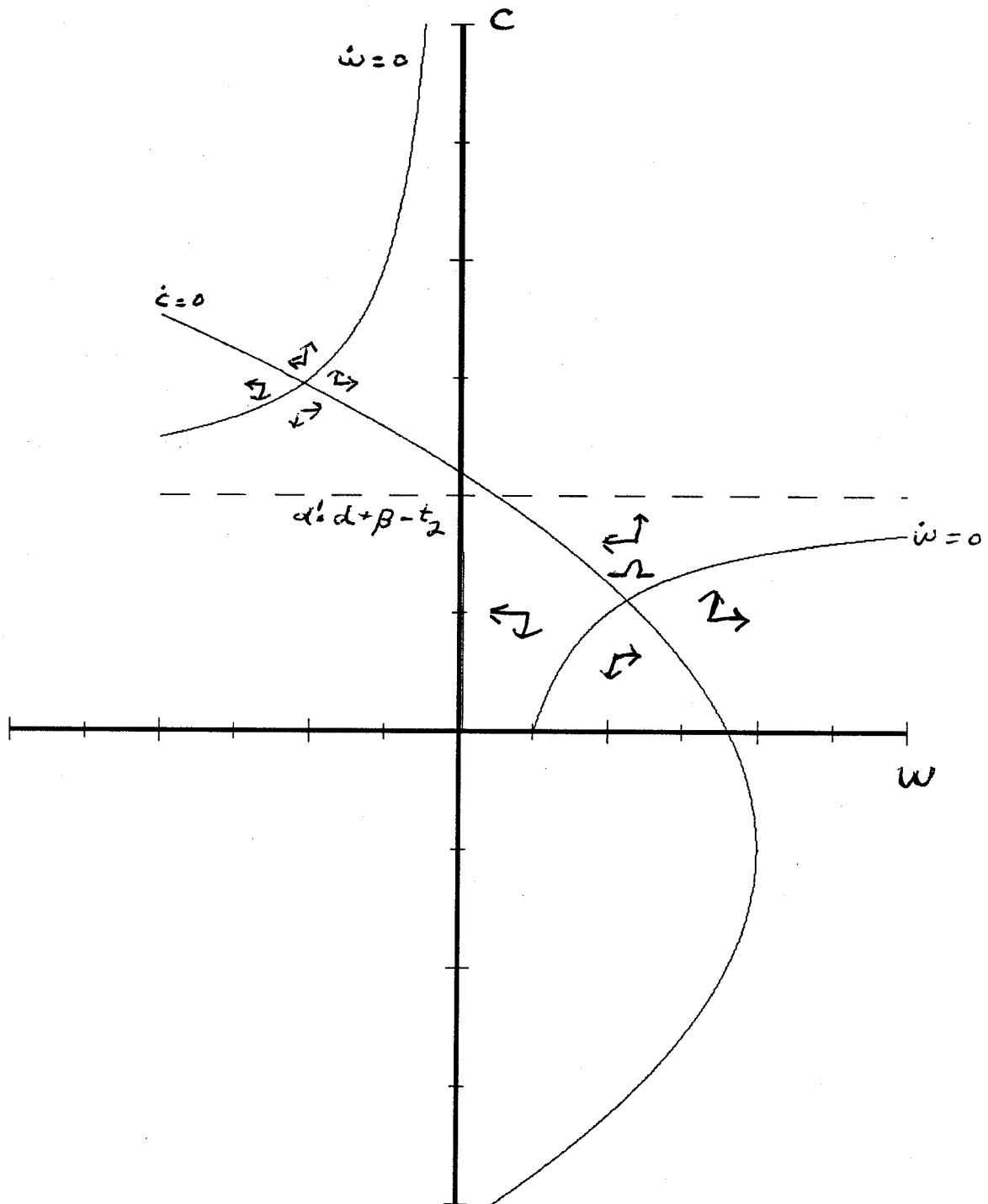

Figure 6b

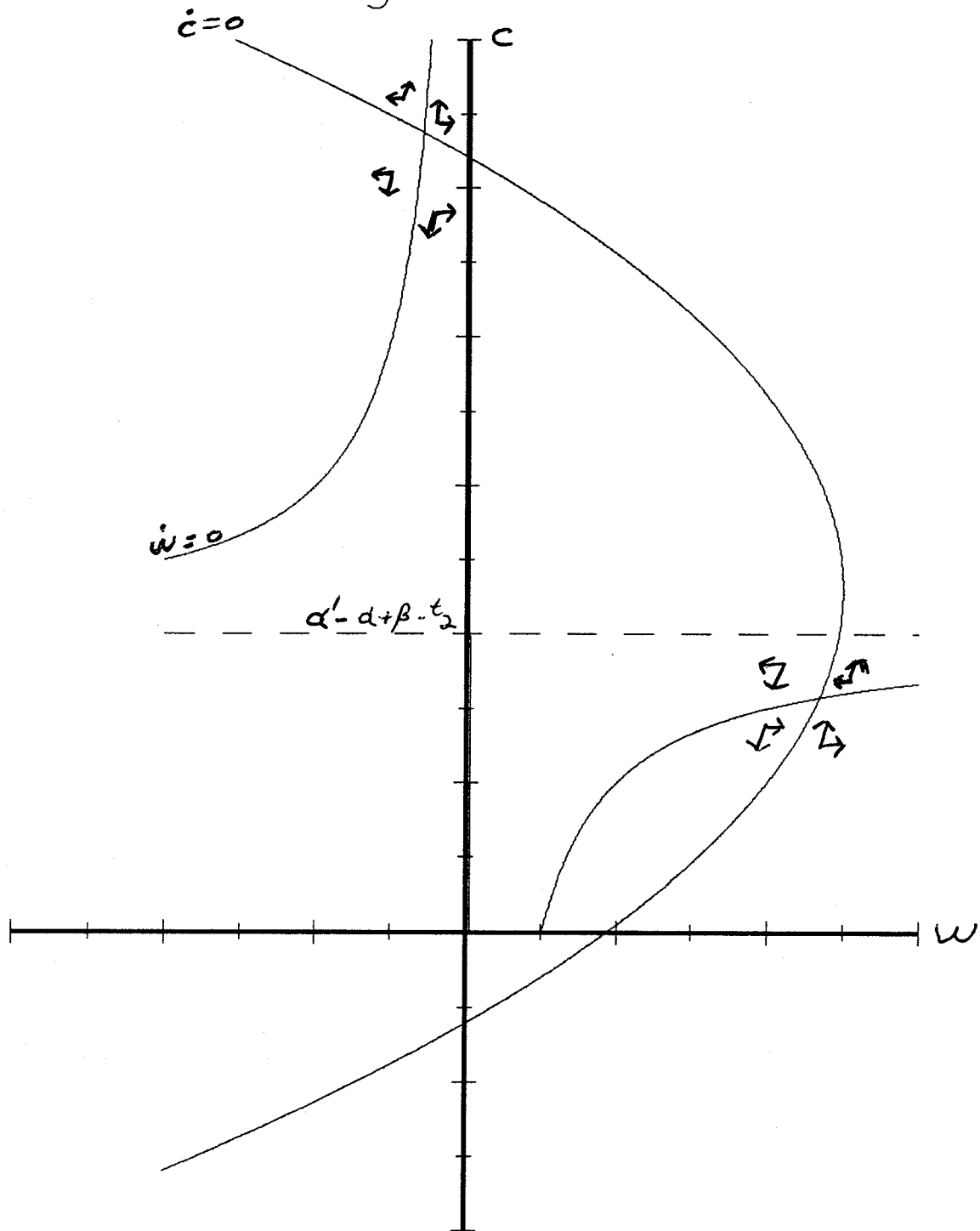

Figure 6c

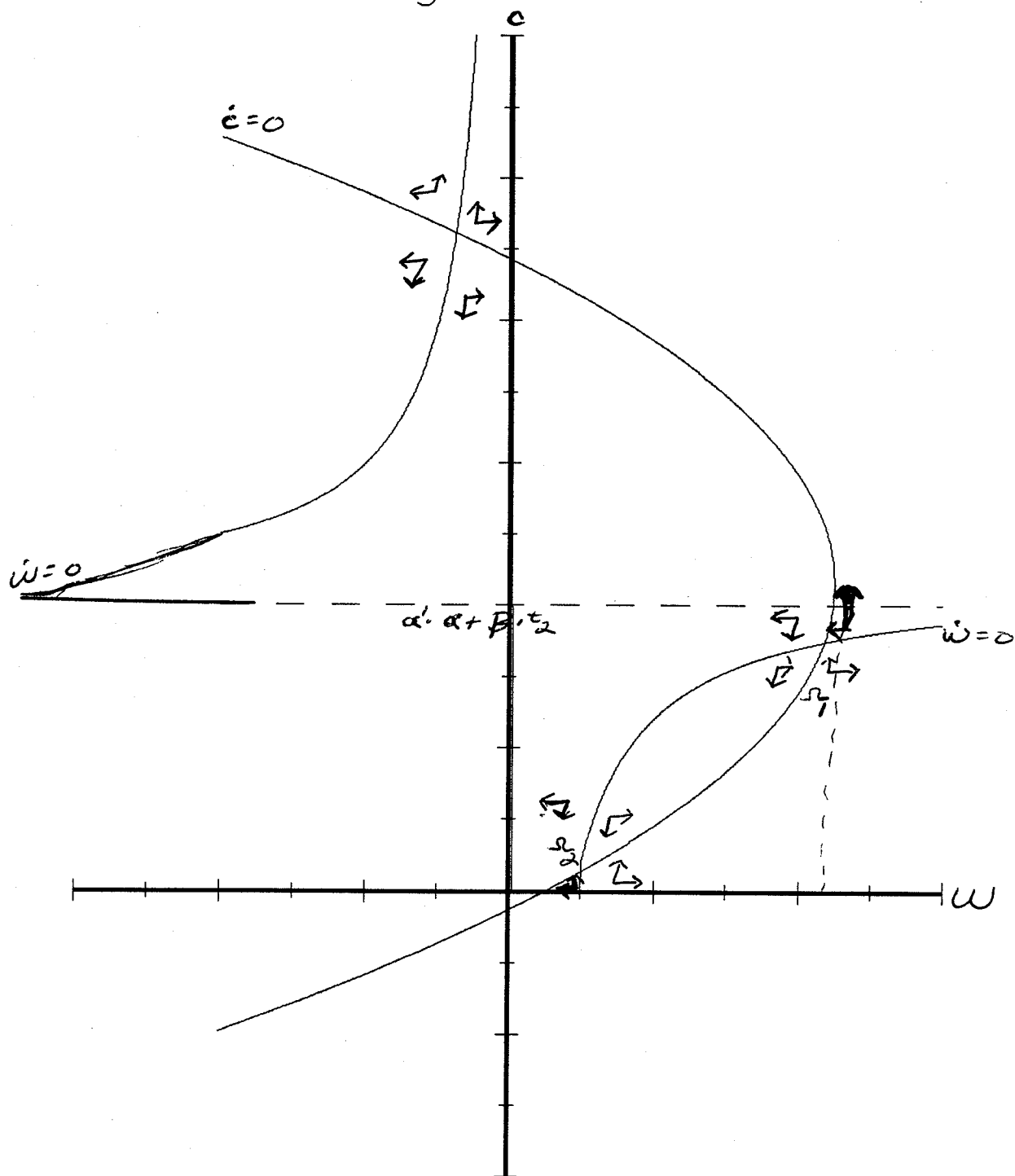

Figure 6d

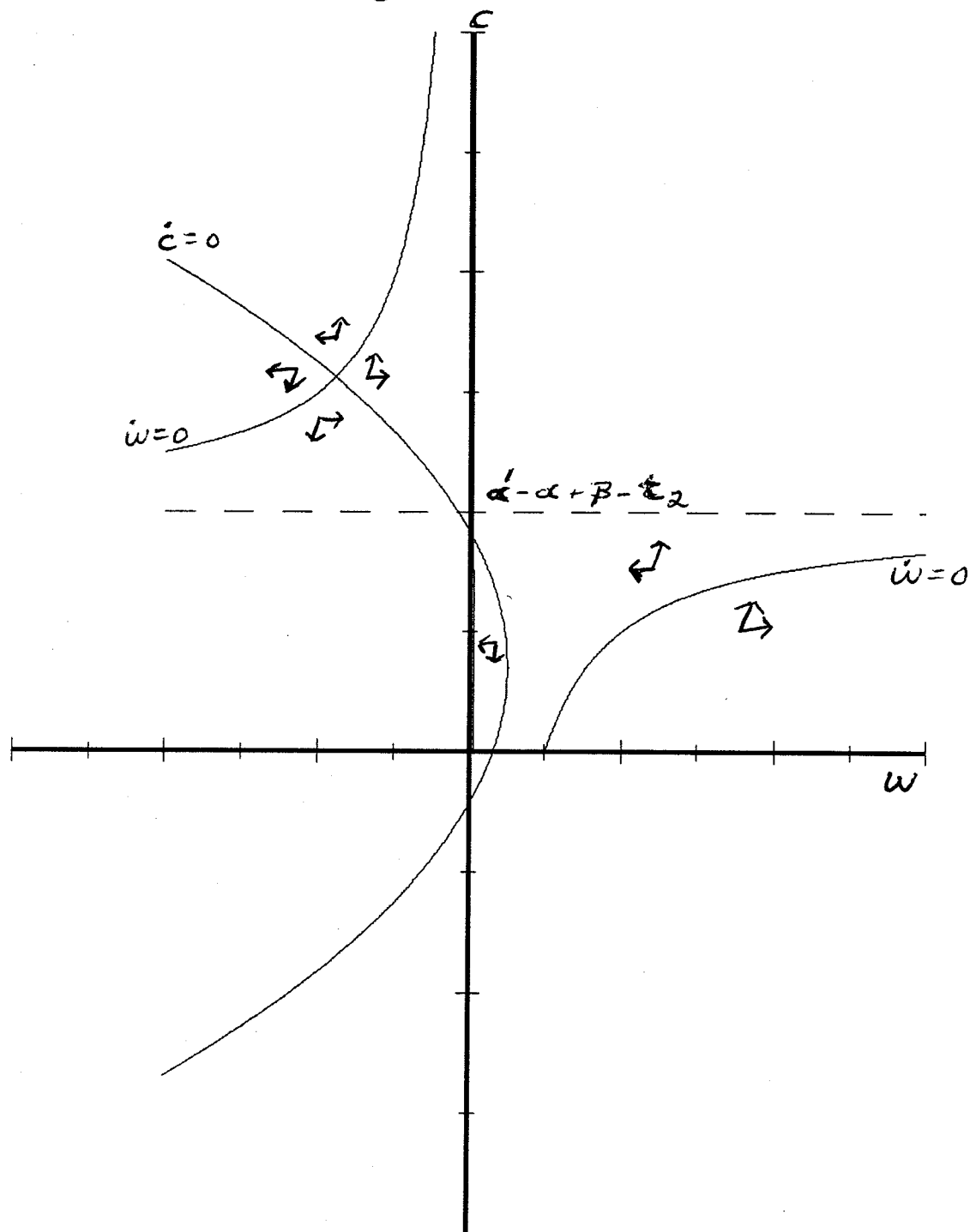

Figure 7

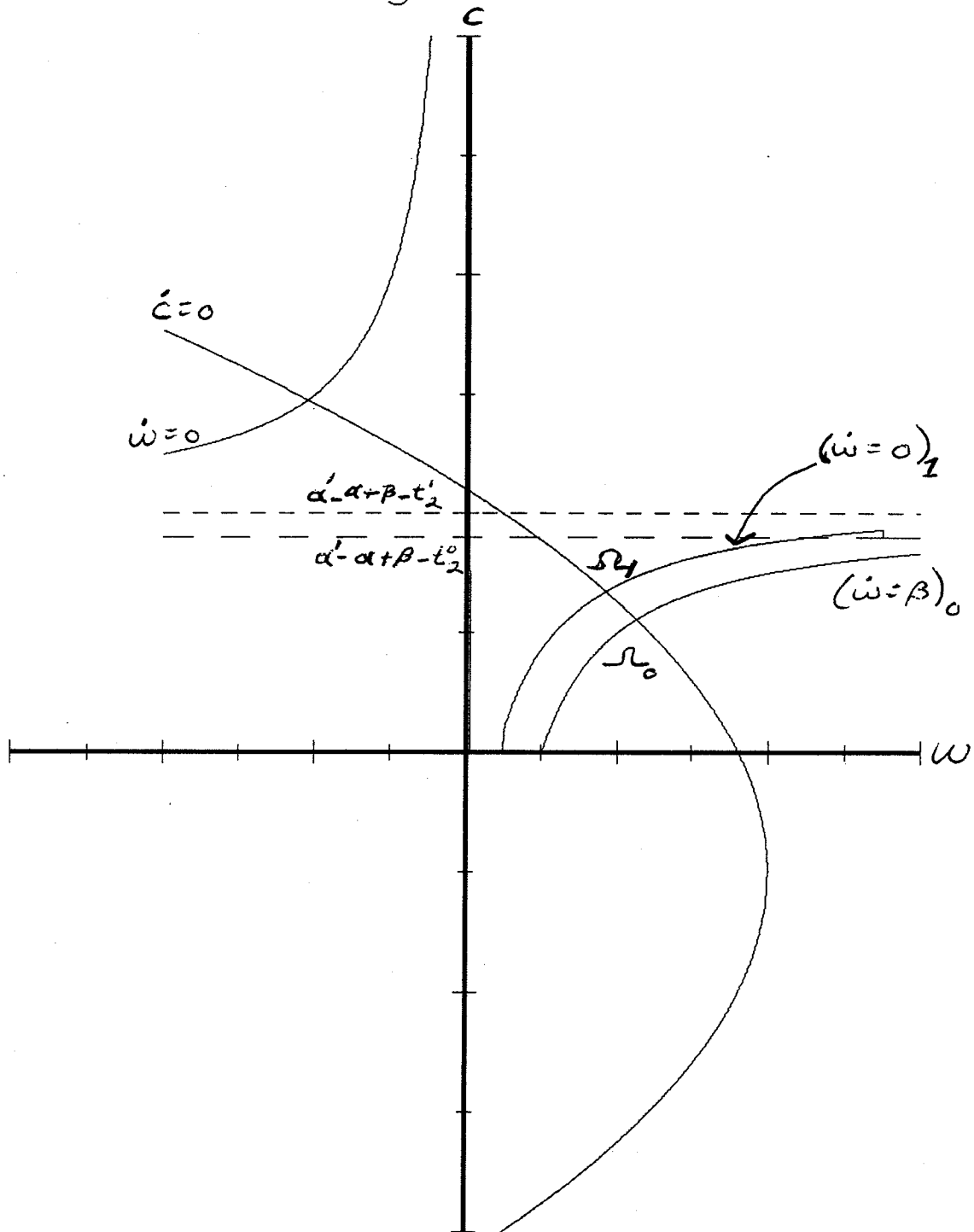

Figure 8

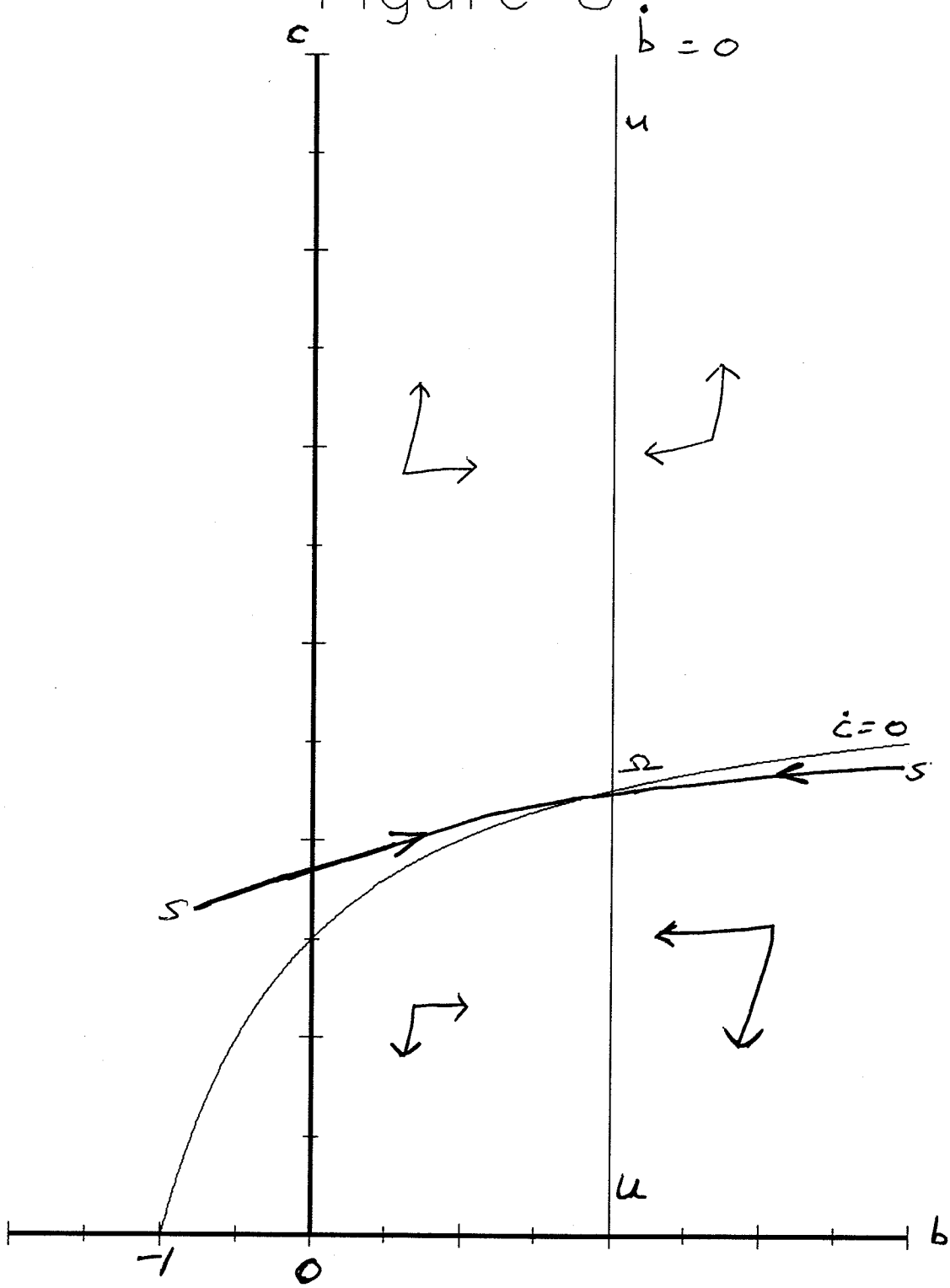

Figure 9

